

**Solarized Elevated water storage of 10,000 liters for Primary Schools**

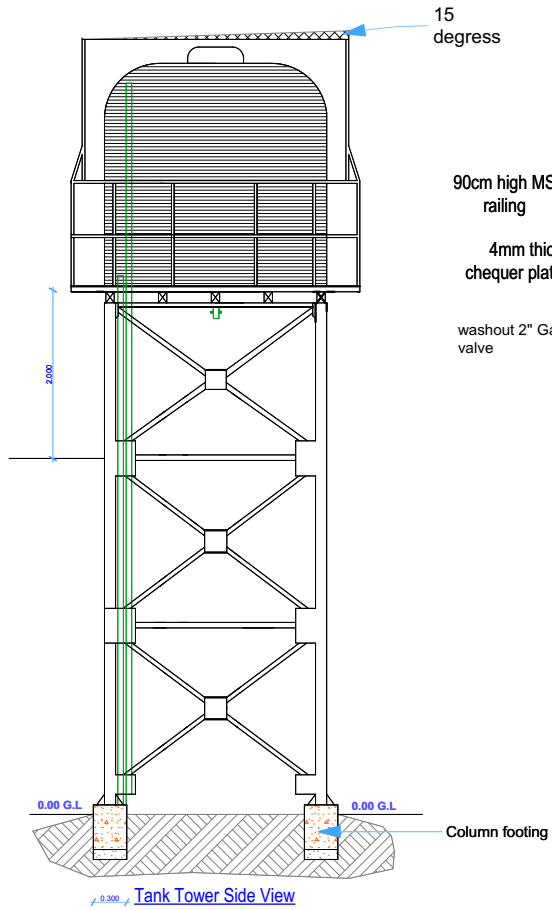

Tank Tower Side View

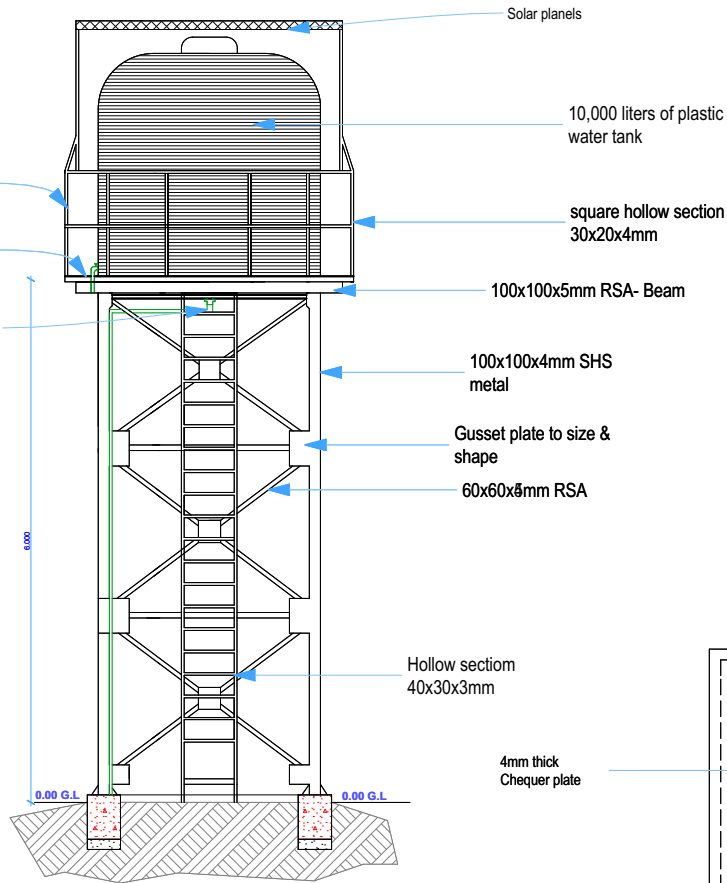

Tank Tower Elevation View

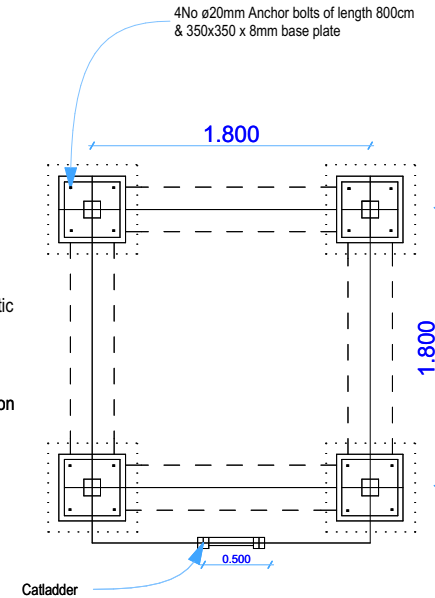

FOUNDATION PLAN  
Scale 1:25

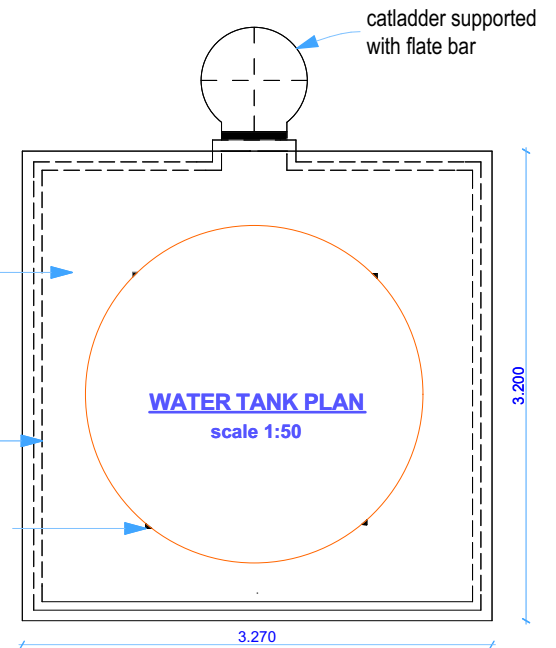

Top View of elevated water tank

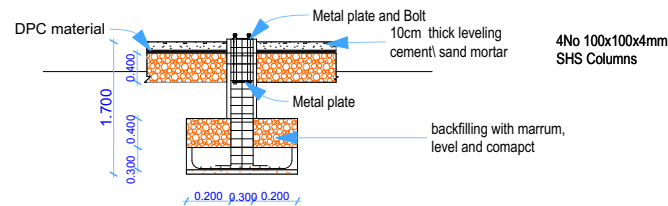

Foundation section

**Detail of Footing:**

- Excavation depth will be determined at the site
- 350x350x 8mm thick base plate with 4No.22mm dia. to receive 4No. 20dia mm bolt
- 4No. 20mm hold down bolts 200mm long per base
- Using Y12- 15cm/C/C- cross- section for the basement
- Using Y12 for square short columns and Y8-15cm-C/C as strip
- footings surrounding is backfilled with marrum
- All dimension are in cm unless otherwise stated