



Tender for Construction of 6 Institutional Pit Latrines (3 Stances) in Khorjamus Market, Makongo Base PHCU, Alur Manyang Market) and Wau County (Bazia Market, Maju Primary School & Farajalla (Congoulesi

Tender Number: WAU/SSDO13 1/0032

Closing Date: 27th April 2022

Table of Content

About Johanniter:	2
Time Table:	2
Instruction to bidders.....	2
Submission of offer.	2
Description of Works/Service.....	2
Tenderers' Eligibility and Qualifications.	2
Selection Criteria.	2
Cost of tendering.....	3
Clarification of Tender Documents.	3
Currencies.....	3
Conditions to Tender.	3
Mandatory documents required for bid submission.....	4
Bidders Signature.	4
Annexes:	4
A: BOQs (Construction of 1 Latrine-3 Stances)	4
B: Latrine design.	4
C: Declaration of Supplier form.....	4



About Johanniter:

Johanniter is a German Christian Not for profit non-governmental organisation running eight integrated projects in former Western Bahr el Ghazal State (WBeG) of South Sudan focusing on maternal and basic health, nutrition (CMAM), WASH and GBV/Protection. Its overall objective is to reduce people's vulnerability, specifically through contributing to morbidity and mortality reduction by improving the population's health and nutrition status. Furthermore, improved access to water, sanitation and hygiene (WASH), and protection services are an existential part of Johanniter's South Sudan programme.

Time Table:

Tender Notice	12 th April 2022
Date line for submission of bids	27 th April 2022
Proposed tender opening dates	02 nd May 2022

Instruction to bidders.

This invitation to tender is open to tenderers eligible and only successful tenderers shall be contact to provide the service as specified in the tender documents.

Please read all instructions, terms and conditions carefully, and ensure your information and documentation is provided on time as failure to do so may result in rejection of your bid.

Submission of offer.

All bids must be submitted to the **Johanniter office in Juba (Plot 60 & 65, Block 3K, Kololo Road)** or **Johanniter Wau office, Sikka Haddid (Former GIZ Office)** or call **0921059597** for directions on or before **27th April 2022, 4:00PM local time** in a sealed envelope clearly marked with the tender number **WAU/SSD0131/0032 – Construction of Institutional Pit Latrines** and sign a document acknowledging submission of your bid at the gate.

Description of Works/Service.

Refer to Annex A & B below for latrine design, BOQs and detailed nature of works required.

Tenderers' Eligibility and Qualifications.

The tenderer shall furnish, as part of its tender documents its qualifications to perform the contract if its tender is accepted. The documentary evidence of the tenderer's qualifications to perform the contract if it's tender is accepted and that the tenderer has the financial and technical capability necessary to perform the contract.

Selection Criteria.

When analysing the offers, Johanniter will take into consideration the following criteria:

1. Price.



JOHANNITER

2. Technical proposal/understanding of works required.
3. Delivery timelines of works required and work plan.
4. Evidence of similar works performed in a similar geographical location and references.

Cost of tendering.

The tenderer shall bear all costs associated with the preparation and submission of the tender. Johanniter will not be responsible or liable for those costs, regardless of the conduct and/ or outcome of the tendering process.

Clarification of Tender Documents.

The prospective tenderer requiring any clarification on the tender documents may notify Johanniter in writing by e-mail to robert.duku@thejohanniter.org with the subject line "**Tender - CLARIFICATION REQUEST - WAU/SSD0131/0032**". The organization will respond through email to any request that it receives earlier than 4 days before the deadline of submission of applications.

Amendments of tender documents.

At any time prior to the deadline for submission of the bids, Johanniter may, for any reason (s), whether at its initiative or in response to a clarification requested by a prospective applicant, notify the tender documents by issuing subsequent addendum. The addendum thus issued shall be part of the tender documents and shall be communicated in writing to all prospective bidders. Prospective bidders shall promptly acknowledge receipt of each addendum in writing. In order to afford prospective applicants reasonable time to take an addendum into account in preparing their applications, the organization may at its discretion, extend the deadline for the submission of bids.

Currencies.

All prices shall be quoted in USD.

Conditions to Tender.

- This tender process shall follow Johanniter's Procurement guidelines and policy and reserves the right to deal with any offer of its choice or any or all parts of the offer.
- Johanniter is not bound to accept the lowest offer or any offer.
- This invitation for tender is not a contract or an offer to a contract, but an invitation to negotiate.
- Respondents are bound by their offer for a period of 90 days as from the closing date of bids.
- Johanniter reserves the right to alter the dates of the timetable.
- Canvassing of Johanniter staff in relation to this tender will result in disqualification of that individual or company.



- Opening of offers is not open to the public and Johanniter will inform each respondent of the results of the decision of their offer.
- Johanniter is not obliged to justify or explain selection to any respondent.

Mandatory documents required for bid submission.

- Financial proposal (Quotation valid for 90 days)
- Work plan clearly stating works timelines
- Company registration certificate/incorporation including Articles & Memorandum of Association.
- Tax registration and clearance certificate.
- Relevant registration/membership from professional regulatory body e.g. Drug regulatory authority, Chambers of commerce etc.
- Trading/operational License.
- Bank statement for at least the last 6 months.
- List of similar contracts in South Sudan including their value, copies of LPOs and contracts (Company name, Business value and contact person).
- Signed and stamped Declaration of Suppliers (*Copy provided below*).
- Signed and stamped Prequalification Questionnaire (*Copy provided below*).

Bidders Signature.

I have read and understood this document and all information provided as part of this tender by our/my company is a true representation.

Signed: _____ Date: _____

Name: _____ Position: _____

Annexes:

- A: BOQs (Construction of 1 Latrine-3 Stances)
- B: Latrine design.
- C: Declaration of Supplier form

JOHANNITER BILL OF QUANTITIES FOR 1 INSTIUTIONAL PIT LATRINE (3 STANCES).

ITEM	DESCRIPTION/SPECIFICATION	UNIT	Qty	RATE (USD)	AMOUNT (USD)
1.0	EARTH WORK				
1.1	Site Preparation: Site clearnes to remove vegatable roots , grass , soil...etc.	Job	1		-
1.2	Excavation: Excavation for a pit 4m deep, 4m long, and 1.50m width including disposal of excavated materials.	M³	24		-
Bill 1	SUB TOTAL 1				-
2.0	CONCRETE WORK (Toilet Slab)				
2.1	Provide all the materials (Cement 42N, Sand, Aggregate, Iron bar y12, and local Poles Binding wire) and cast Toilet slab (4.60m x 2.10m x 0.10m) Reinforced Concrete Mix and lay in position as per specification: reinforced concrete; grade 25, include for Reinforcement, a high tensile steel bars; grade 460 n/mm2;to conform with the relative British Standard Specifications. (Mix 1:2:4).	M³	1		0
Bill 2	SUB TOTAL 2				-
3.0	MASONRY WORKS				
3.1	Provide all the materials (Red bricks, Cement 42N, and Sand) and Build one red brick wall including pit lining, plinth wall and curtin walls thickness of 0.20m, and Hand washing facility as in Drawings using cement-sand mator mix 1:4	M²	52		-
Bill 3	SUB TOTAL 3				-
4.0	ROOFING WORKS:				
4.1	Roof (structure, cover): provide in position all roofing structures tools as spcified , (timber must be swan mahogany, Fecia board, roofing sheet approved colour, Vent Pipe 4" with screen cover, and assorted nails completed with all necessary required) and construct the roof according to the drawings.	M²	13		0
Bill 4	SUB TOTAL 4				0
5.0	FINISHING WORKS				
5.1	Plastering: Provide all the materials (Cement42, and sand) and apply 15mm thick plaster to internal and external walls with cement sand mix 1:4 steel trowel smooth.	M²	85		0
5.2	Floor screeding: Cement and sand mix 1:4 screed as described 10mm thick steel trowel smooth in all floor bed.	M²	14		0
5.3	Painting Works: Provide all the materials (under coat, Emolosin, Oil Paint for skirting and Weather Guard) and apply paint 3 coats high quality pomastic paint in approved colour to reach smooth finishes for internal walls and wheather guard for external walls.				
5.3.1	Painting for internal Walls	M²	45		0
5.3.2	Painting for external Walls	M²	40		0
Bill 5	SUB TOTAL 5				0
6.0	FITTINGS				

6.1	Doors: Provide and fix complete metal door size 1.8m x 0.70m	Each	3		0
6.2	High Level Window: Provide and fix complete metal High level window size 0.30m x 0.30m	sum	3		0
Bill 6	SUB TOTAL 6				0
	SUMMARY TO BoQ				AMOUNT (USD)
Bill 1	EARTH WORK				-
Bill 2	CONCRETE WORK (Toilet Slab)				-
Bill 3	MASONRY WORKS				-
Bill 4	ROOFING WORKS:				-
Bill 5	FINISHING WORKS				-
Bill 6	FITTINGS				-
	TOTAL FOR 01 INSTIUTIONAL PIT LATRINE (3 STANCES).				-
	GRAND TOTAL FOR 6 PIT LATRINES (3 STANCES).				-

Annex I: PIT LATRINE drawing

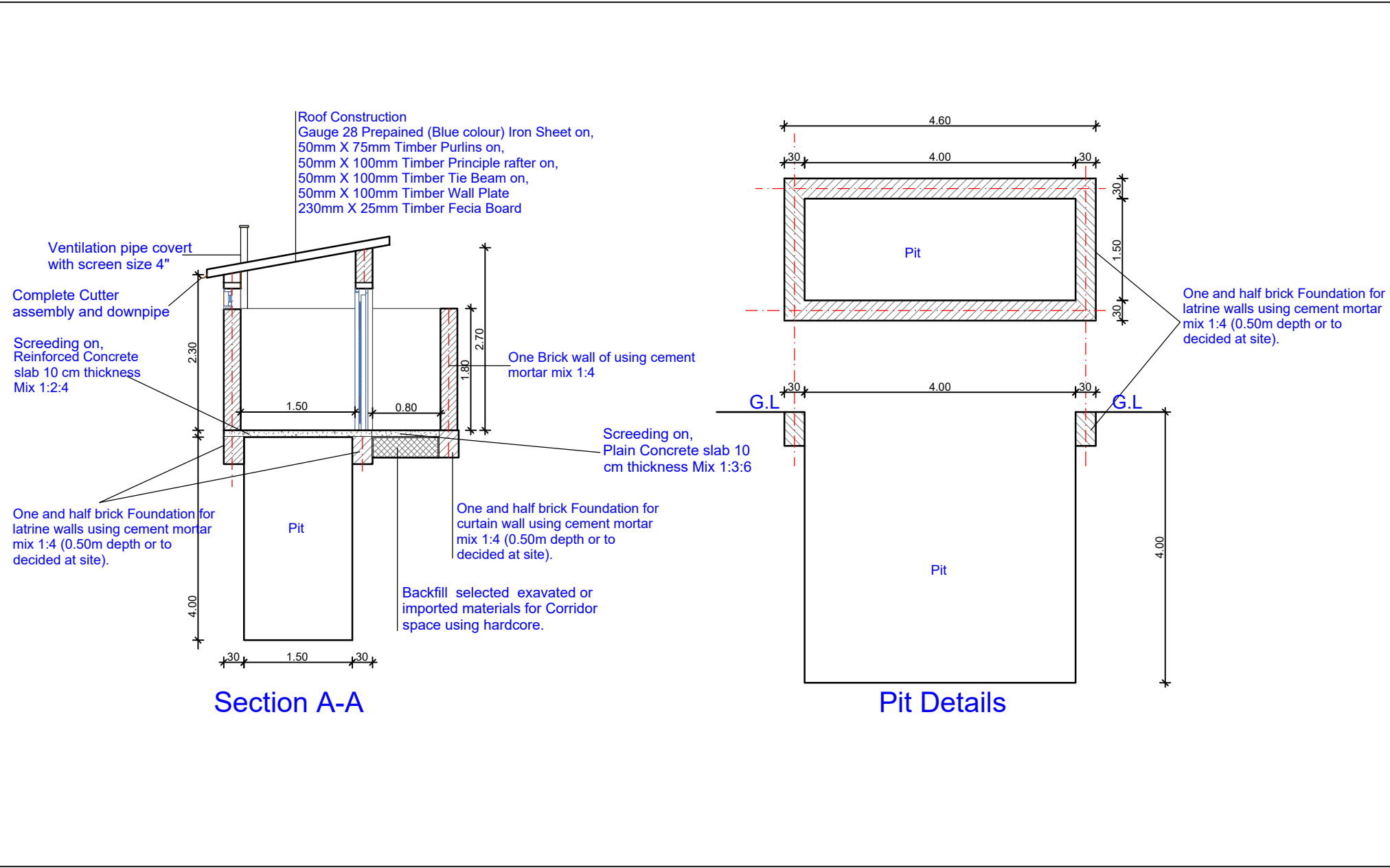

Project Name :
 Construction of Institutional Pit
 latrine (3 Stances)

Drawn by:
 Edwin Paul Mangu

Sheet Name:
 Section and Details

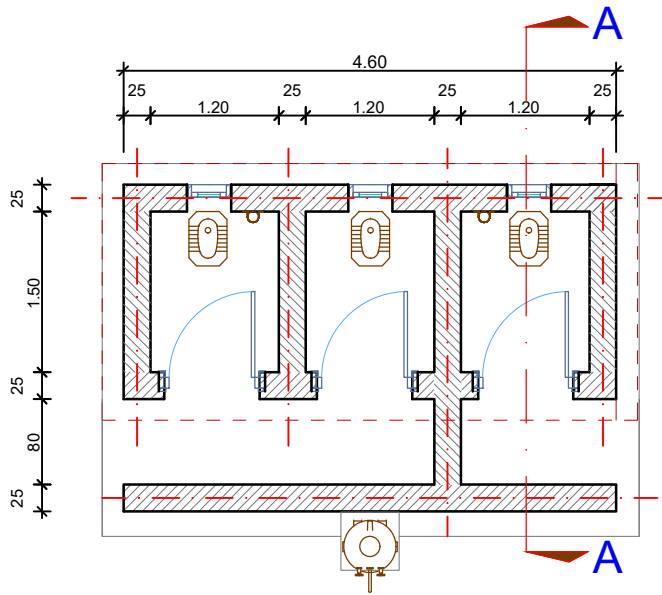

Plan

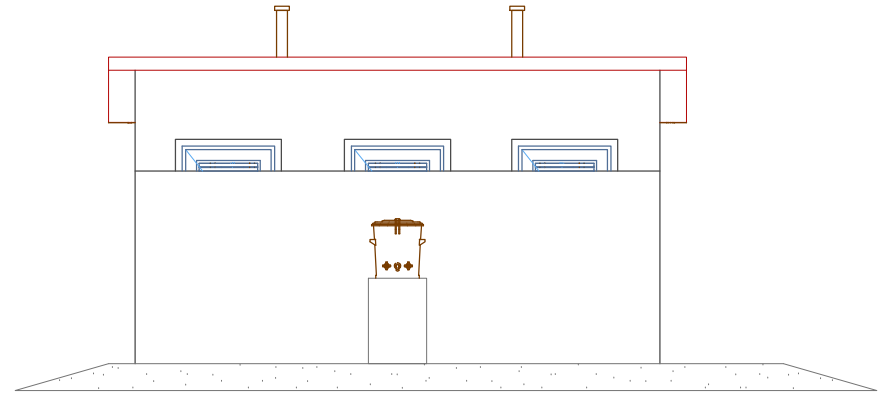

Front Elevation

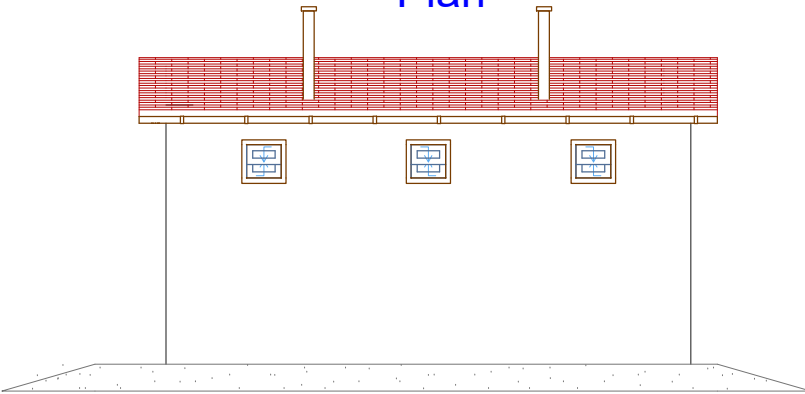

Back Elevation

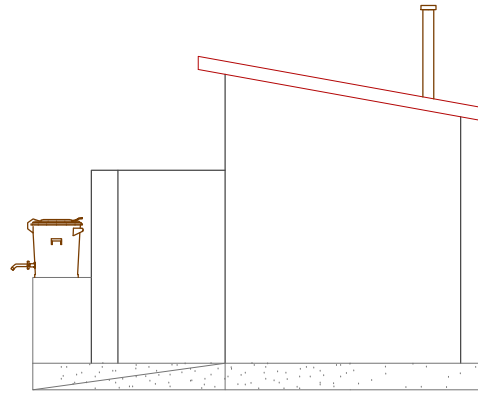

Right Elevation

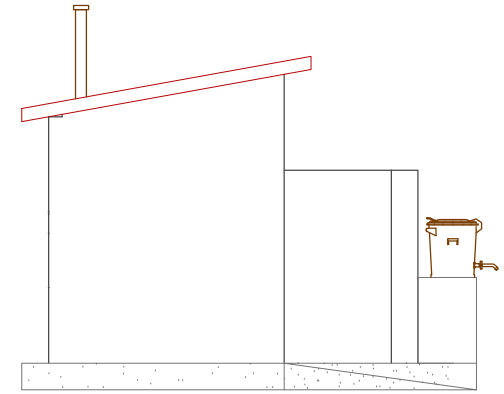

Left Elevation

Project Name :
Construction of Institutional Pit
latrine (3 Stances)

Drawn by:
Edwin Paul Mangu

Sheet Name:
Plan and Elevations



DECLARATION OF SUPPLIERS

We _____ [company name] _____ herewith declare that

- a) we do respect basic social rights and working conditions based on international labour standards and condemn the exploitation of child labour;
- b) we are not bankrupt or being wound up, are not having our affairs administered by the courts, have not entered into an arrangement with creditors, have not suspended business activities, are not the subject of proceedings concerning those matters, and are not in any analogous situation arising from a similar procedure provided for in national legislation or regulations;
- c) we have not been convicted of an offence concerning our professional conduct by a judgment which has the force of res judicata;
- d) we have not been guilty of grave professional misconduct;
- e) we have fulfilled all obligations relating to the payment of social security contributions or the payment of taxes in accordance with the legal provisions of the country in which we are established or with the Federal Republic of Germany or those of the country where the contract is to be performed;
- f) we have not been the subject of a judgment which has the force of res judicata for fraud, corruption, involvement in a criminal organisation or any other illegal activity detrimental to Johanniter's financial interests;
- g) following another procurement procedure carried out by Johanniter or another contracting authority, we have not been declared to be in serious breach of contract for failure to comply with our contractual obligations;
- h) we are not subject to a conflict of interest with regard to this tender. We declare that the price on the bid attached is a market competitive offer from my organization, and we are submitting to this procurement process without any conflict of interest, or the provision / receipt of any commission, gift, bribe, gratuity or remuneration of any kind.
- i) we are not guilty of misrepresentation in supplying the information required by Johanniter as a condition of participation in the contract procedure.
- j) we do not perform any act or omit to perform any act, including any misrepresentation, in order to knowingly mislead, or attempt to knowingly mislead JOHANNITER and/or any other party to obtain a financial or other benefit or to avoid any obligation ("Fraudulent Practice");
- k) we do not offer, give, receive or solicit, directly or indirectly, or attempt to offer, give, receive or solicit, directly or indirectly, anything of value to improperly influence the actions of JOHANNITER and/or any other party ("Corrupt Practice");
- l) we do not enter into any arrangements with any other party or parties that are designed to achieve an improper purpose, including but not limited to improperly influencing the actions of JOHANNITER and/or any other party or engaging in price fixing ("Collusive Practice", and together

- with “Fraudulent Practices and Corrupt Practices”, “Prohibited Practices”).
- m) we do not engage in transactions with, or provide resources or support to, individuals and organizations associated with terrorism, whether in cash or in kind, directly or indirectly.
 - n) we verify that no support or resources are provided to individuals or entities associated with terrorism as designated on the „Consolidated list of persons, groups and entities subject to EU financial sanctions” maintained by the European Commission or by any other similar sanction list of individuals and entities that may be established by the United Nations Security Council or the United States of America.
 - o) we do not engage in acts that directly support or advance trafficking in persons, including the following acts:
 - i destroying, concealing, confiscating, or otherwise denying an employee access to that employee’s identity or immigration documents;
 - ii. failing to provide return transportation or pay for return transportation costs to an employee from a country to the country from which the employee was recruited upon the end of employment if requested by the employee.
 - iii. soliciting a person for the purpose of employment, or offering employment, by means of materially false or fraudulent pretences, representations, or promises regarding that employment.
 - p) we do respect applicable law relating to anti-money laundering in the execution of our contracts.

General statements:

- 1.1 The contractor shall communicate these fundamentals of JOHANNITER’s Policy to its management, employees, subcontractors and agents and shall take all reasonable measures to ensure that such persons do not engage in prohibited practices.
- 1.2 The contractor shall immediately disclose to JOHANNITER any actual, apparent, potential or attempted prohibited practice that the contractor becomes aware of. To that end, the contractor shall fully cooperate, and shall take all reasonable steps to ensure that its management, employees, subcontractors and agents fully cooperate with any investigation of prohibited practices by JOHANNITER, including by complying with all reasonable requests from JOHANNITER to gain access to and inspect any records, documents and other relevant information.
- 1.3 JOHANNITER is committed to the protection of vulnerable populations in humanitarian crisis, including from sexual exploitation and abuse. By entering into a contract with JOHANNITER, The contractor undertakes to ensure that

its personnel, agents and subcontractors conform to the highest standards of moral and ethical conduct.

The contractor expressly acknowledges and agrees that:

- a) Any breach of this policy by the contractor or by any of its management, employees, subcontractors or agents constitutes a material breach of the contracts, which entitles JOHANNITER to immediately terminate a contract without incurring any liability to the contractor; and
- b) In the event that JOHANNITER were to determine through an investigation or otherwise that a prohibited practice occurred, JOHANNITER shall have, in addition to its right to immediately terminate the contract, the rights to:
 - i. apply and enforce the relevant sanctions in accordance with its internal regulations, rules, procedures, practices, policies and guidelines, including referral of the matter to national authorities when appropriate; and
 - ii. recover all losses, financial or otherwise, suffered by JOHANNITER in connection with such prohibited practices.

Date & Signature

Name of company

Name in printed letters

Stamp