

1 ROOF LAYOUT PLAN
1 : 75

GENERAL NOTES

- USE CONCRETE C-25 FOR COLUMNS, SLABS, BEAMS, AND FOOTING
- USE CONCRETE C-5 FOR LEAN CONCRETE
- USE 25mm CONCRETE COVER TO BEAMS, COLUMNS & SLAB
- USE 40mm CONCRETE COVER TO FOOTINGS
- USE CLASS S-400 DEFORMED REINFORCEMENT BARS REINFORCING STEEL $F_y = 400N/MM^2$
- ACTUAL SOIL BEARING CAPACITY SHALL BE CHECKED BY THE SUPERVISING ENGINEER DURING ACTUAL EXCAVATION FOR FOUNDATION.
- MAXIMUM SIZE OF AGGREGATE = 20mm
- FOUNDATION DEPTH SHALL BE DECIDED BY THE ENG. ON SITE
- ALL DIMENSIONS ARE IN mm BE SCALED
- THE DIMENSIONS IN DRAWINGS SHOULD NOT
- THIS DRAWING SHOULD READ IN CONNECTION WITH ARCHITECTURAL, SANITARY, AND ELECTRICAL

No.	Date	Description

Drawing status
STRUCTURAL DRAWING

CLIENT
ACTED SOUTH SUDAN

CONSULTANT
LADDER FOR ENGINEERING AND GENERAL INVESTMENT CO.LTD

PROJECT
FRUIT PROCESSING UNIT

LOCATION
MARIDI, MARIDI COUNTY, WEST EQUATORIA, RSS

DRAWING TITLE
ROOF LAYOUT PLAN

DESIGN & DRAWING BY. _____ Date _____
LADDER ENGINEERING

CHECKED & APPROVED BY _____ Date _____

Scales
AS SHOWN

Layout ID. _____ Revision _____
A01-1

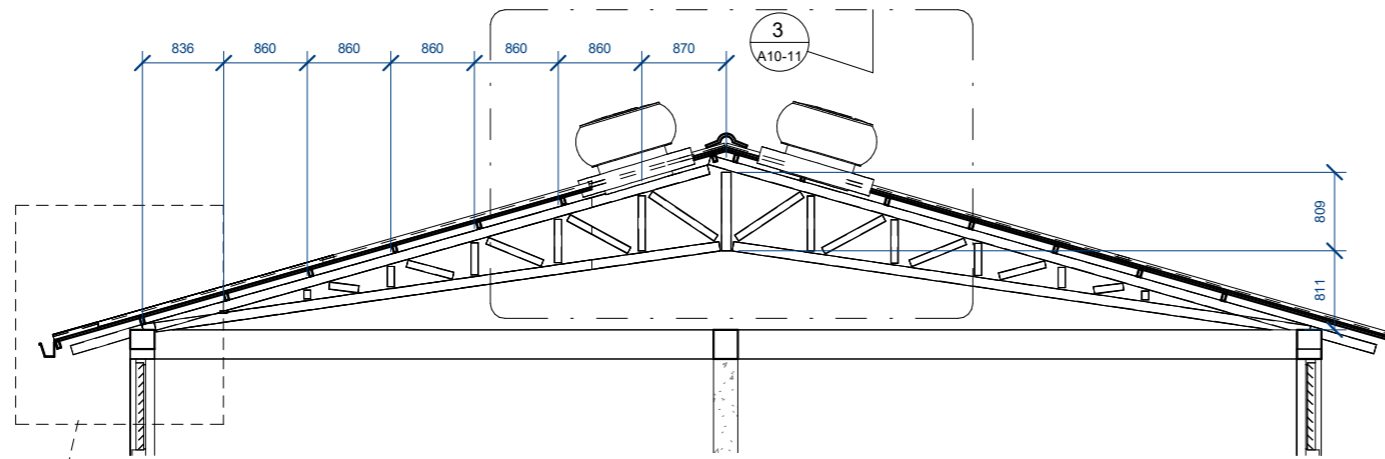

ROOF TRUSS (T1) PLAN (9PCS)

SCALE 1:50

A01-7

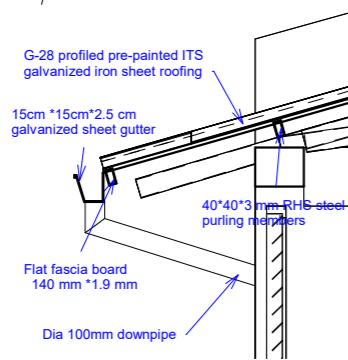

2 Gutter Detail

1 : 25

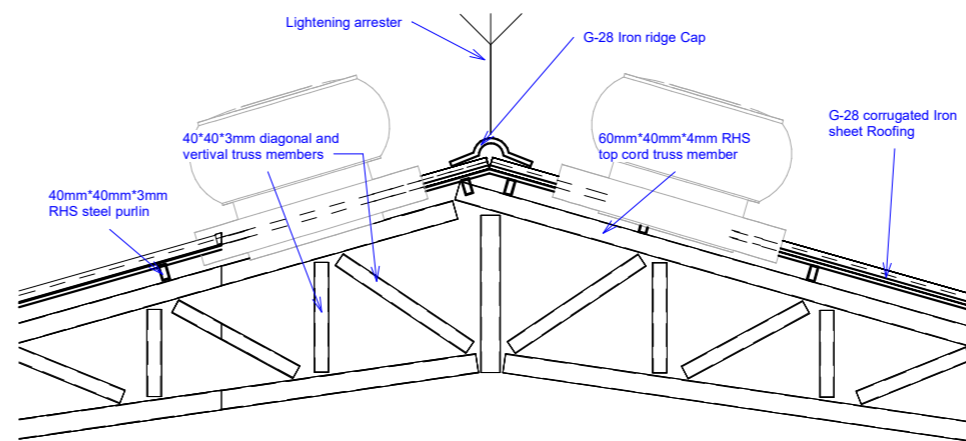

RIDGE DETAILS

SCALE 1:25

GENERAL NOTES

- USE CONCRETE C-25 FOR COLUMNS, SLABS, BEAMS, AND FOOTING
- USE CONCRETE C-5 FOR LEAN CONCRETE
- USE 25mm CONCRETE COVER TO BEAMS, COLUMNS & SLAB
- USE 40mm CONCRETE COVER TO FOOTINGS
- USE CLASS S-400 DEFORMED REINFORCEMENT BARS
- REINFORCING STEEL FY=400N/MM2
- ACTUAL SOIL BEARING CAPACITY SHALL BE CHECKED BY THE SUPERVISING ENGINEER DURING ACTUAL EXCAVATION FOR FOUNDATION.
- MAXIMUM SIZE OF AGGREGATE =20mm
- FOUNDATION DEPTH SHALL BE DECIDED BY THE ENG. ON SITE
- ALL DIMENSIONS ARE IN mm
- THE DIMENSIONS IN DRAWINGS SHOULD NOT BE SCALED
- THIS DRAWING SHOULD READ IN CONNECTION WITH ARCHITECTURAL, SANITARY , AND ELECTRICAL

No.	Date	Description
-----	------	-------------

Drawing status
STRUCTURAL DRAWING

CLIENT
ACTED SOUTH SUDAN

CONSULTANT
LADDER FOR ENGINEERING AND GENERAL INVESTMENT CO.LTD

PROJECT
FRUIT PROCESSING UNIT

LOCATION
MARIDI, MARIDI COUNTY, WESTEQUATORIA, RSS

DRAWING TITLE
ROOF TRUSS DETAILS

DESIGN & DRAWING BY. _____ Date _____

LADDER ENGINEERING

CHECKED & APPROVED BY _____ Date _____

Scales
AS SHOWN

Layout ID. _____ Revision _____
A01-2

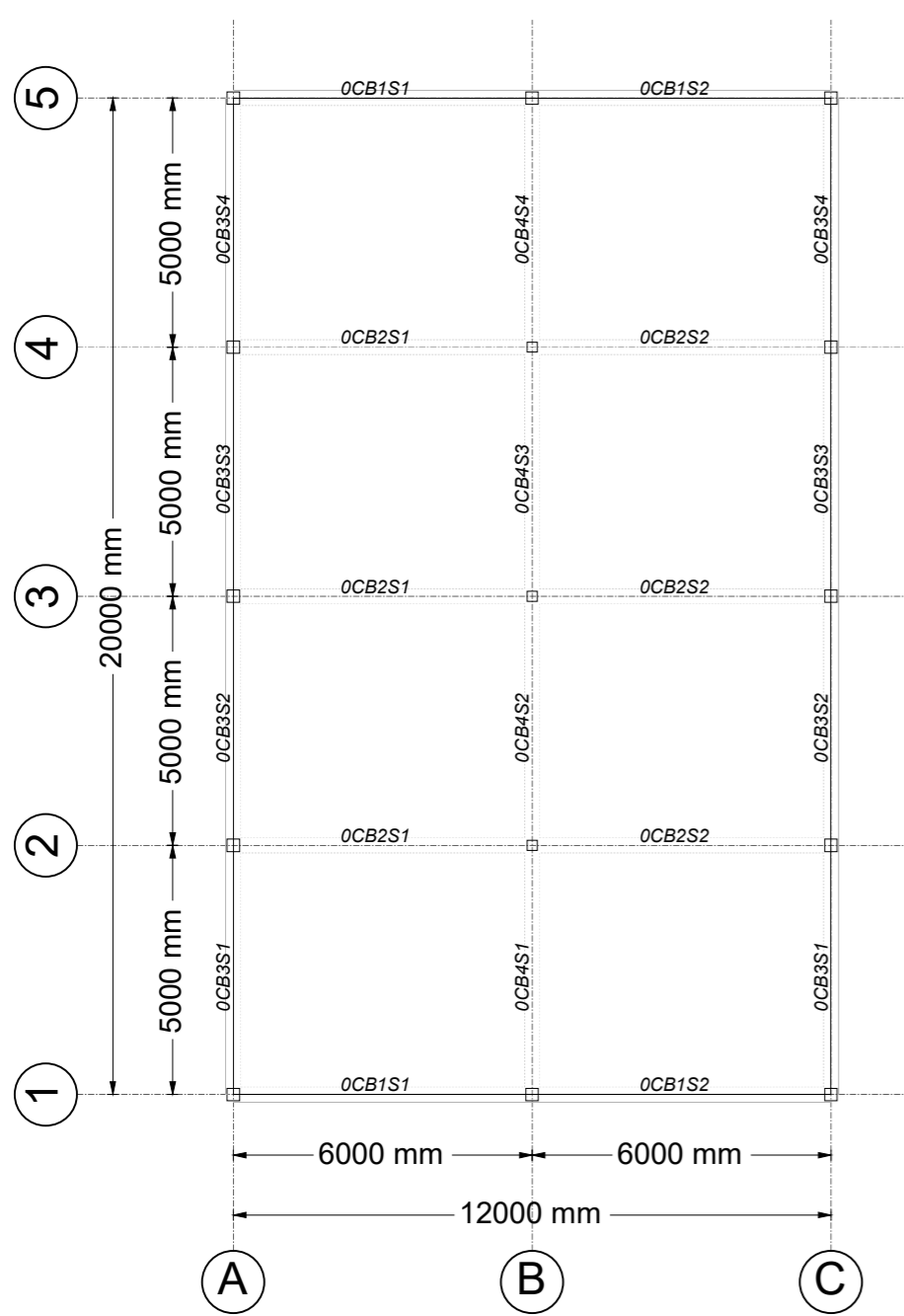

Concrete Beam Layout - Base (EL. 0 mm)
(Scale = 1:75)

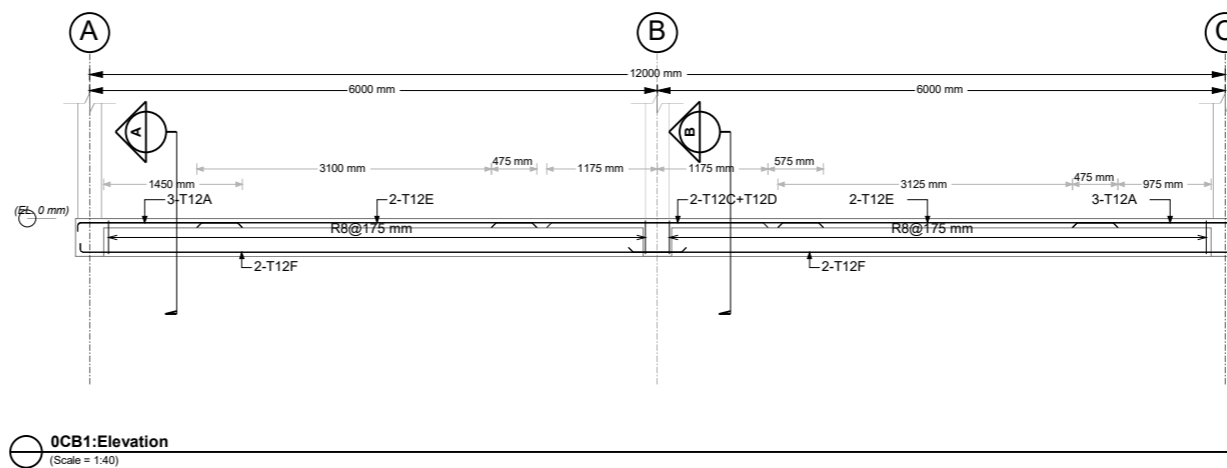

0CB1:Elevation
(Scale = 1:40)

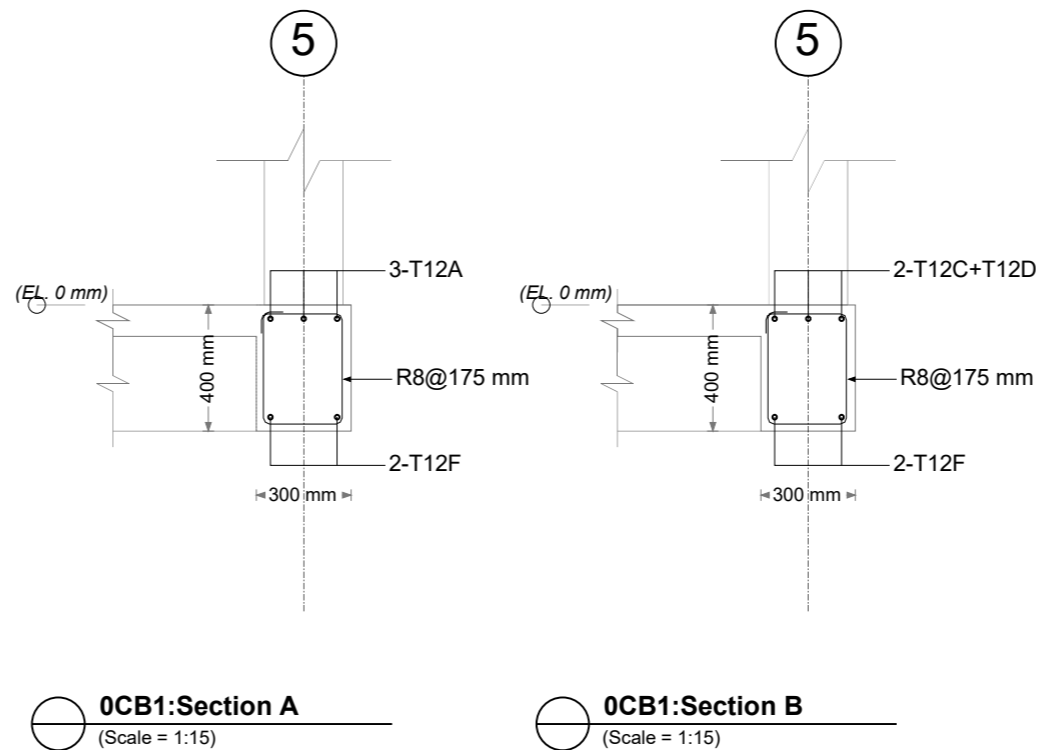

0CB1:Section A
(Scale = 1:15)

0CB1:Section B
(Scale = 1:15)

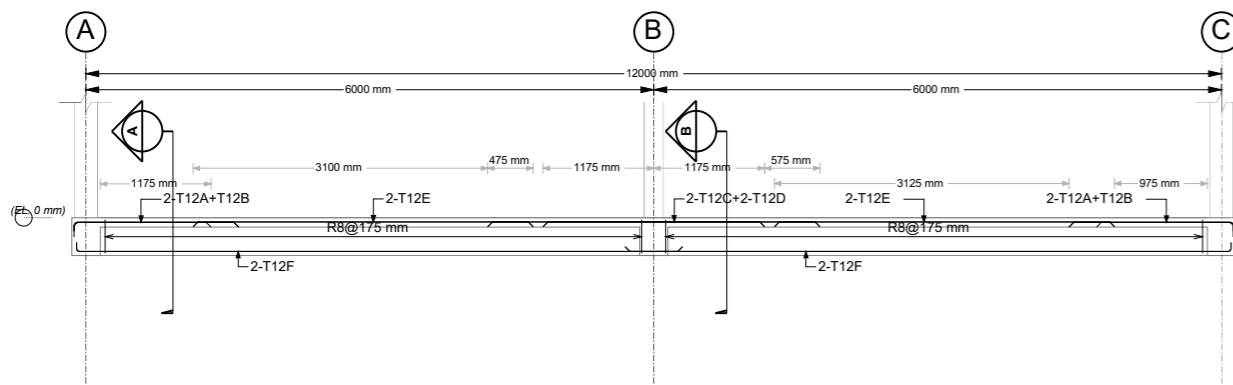

0CB2:Elevation
(Scale = 1:40)

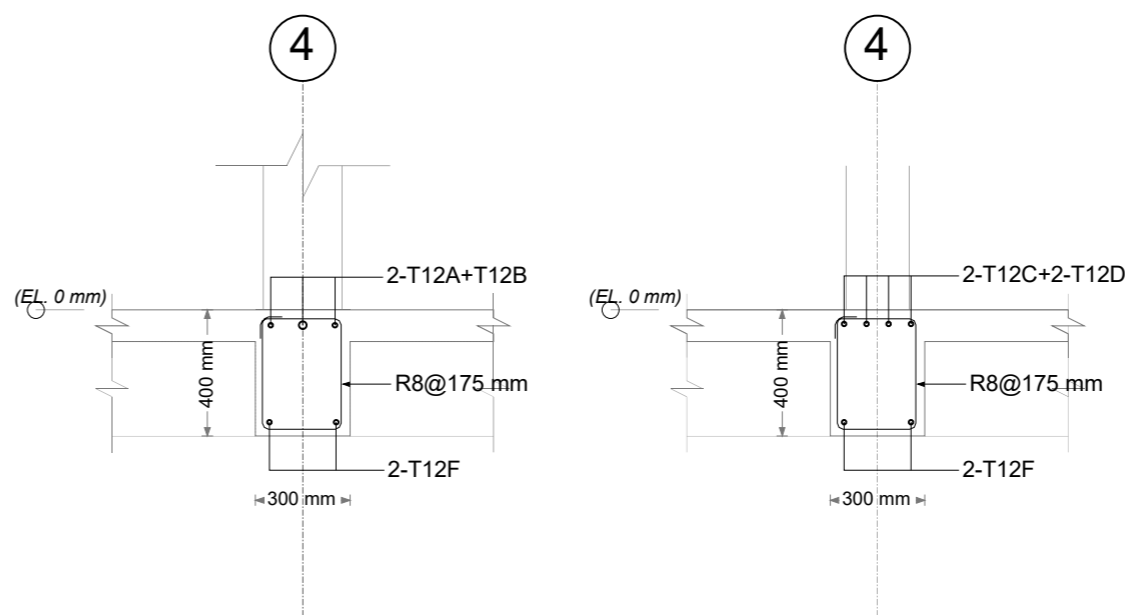

0CB2:Section A
(Scale = 1:15)

0CB2:Section B
(Scale = 1:15)

GENERAL NOTES

- USE CONCRETE C-25 FOR COLUMNS, SLABS, BEAMS, AND FOOTING
- USE CONCRETE C-5 FOR LEAN CONCRETE
- USE 25mm CONCRETE COVER TO BEAMS, COLUMNS & SLAB
- USE 40mm CONCRETE COVER TO FOOTINGS
- USE CLASS S-400 DEFORMED REINFORCEMENT BARS REINFORCING STEEL $F_y=400N/MM^2$
- ACTUAL SOIL BEARING CAPACITY SHALL BE CHECKED BY THE SUPERVISING ENGINEER DURING ACTUAL EXCAVATION FOR FOUNDATION.
- MAXIMUM SIZE OF AGGREGATE = 20mm
- FOUNDATION DEPTH SHALL BE DECIDED BY THE ENG. ON SITE
- ALL DIMENSIONS ARE IN mm
- BE SCALED
- THE DIMENSIONS IN DRAWINGS SHOULD NOT
- THIS DRAWING SHOULD READ IN CONNECTION WITH ARCHITECTURAL, SANITARY, AND ELECTRICAL

No.	Date	Description
-----	------	-------------

Drawing status
STRUCTURAL DRAWING

CLIENT
ACTED SOUTH SUDAN

CONSULTANT
LADDER FOR ENGINEERING AND GENERAL INVESTMENT CO.LTD

PROJECT
FRUIT PROCESSING UNIT

LOCATION
MARIDI, MARIDI COUNTY, WESTEQUATORIA, RSS

DRAWING TITLE
RC Frame layout, Elevations and Sections

DESIGN & DRAWING BY. _____ Date _____
LADDER ENGINEERING

CHECKED & APPROVED BY _____ Date _____

Scales
AS SHOWN

Layout ID. _____ Revision _____

A02-1

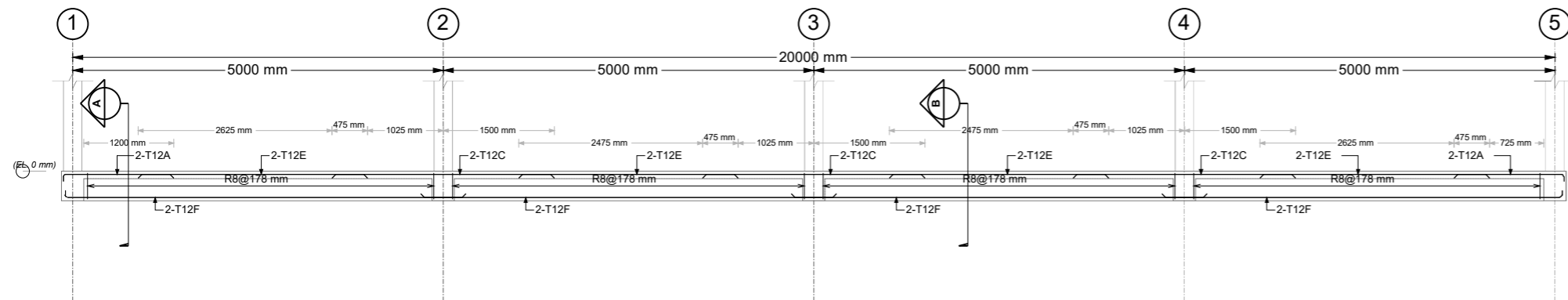

0CB3:Elevation
(Scale = 1:40)

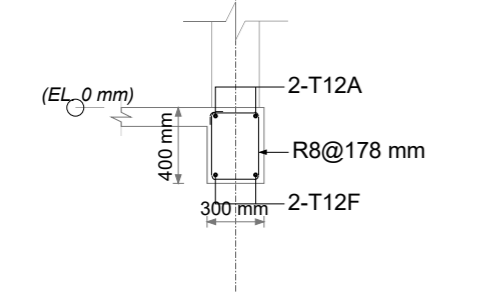

0CB3:Section A
(Scale = 1:20)

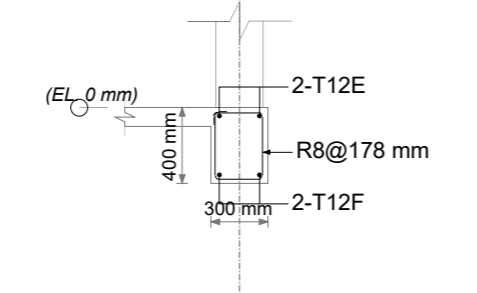

0CB3:Section B
(Scale = 1:20)

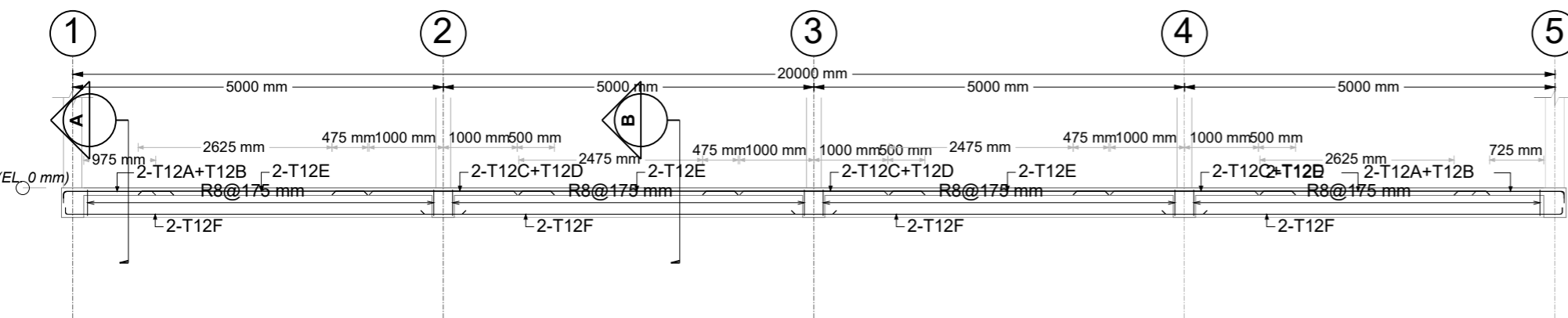

0CB4:Elevation
(Scale = 1:40)

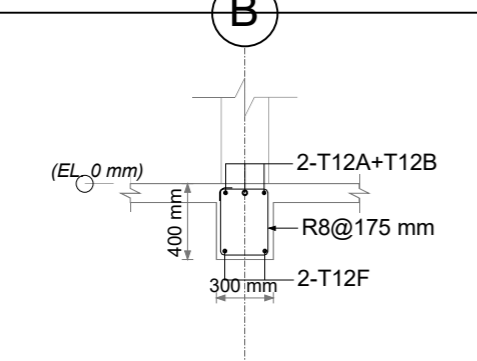

0CB4:Section A
(Scale = 1:20)

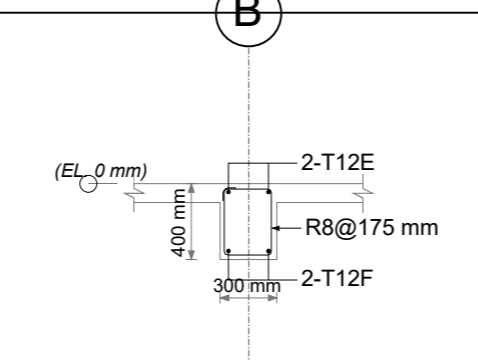

0CB4:Section B
(Scale = 1:20)

GENERAL NOTES

- USE CONCRETE C-25 FOR COLUMNS, SLABS, BEAMS, AND FOOTING
- USE CONCRETE C-5 FOR LEAN CONCRETE
- USE 25mm CONCRETE COVER TO BEAMS, COLUMNS & SLAB
- USE 40mm CONCRETE COVER TO FOOTINGS
- USE CLASS S-400 DEFORMED REINFORCEMENT BARS
- REINFORCING STEEL FY=400N/MM²
- ACTUAL SOIL BEARING CAPACITY SHALL BE CHECKED BY THE SUPERVISING ENGINEER DURING ACTUAL EXCAVATION FOR FOUNDATION.
- MAXIMUM SIZE OF AGGREGATE =20mm
- FOUNDATION DEPTH SHALL BE DECIDED BY THE ENG. ON SITE
- ALL DIMENSIONS ARE IN mm
- BE SCALED
- THE DIMENSIONS IN DRAWINGS SHOULD NOT BE SCALED
- THIS DRAWING SHOULD READ IN CONNECTION WITH ARCHITECTURAL, SANITARY, AND ELECTRICAL

No.	Date	Description

Drawing status
STRUCTURAL DRAWING

CLIENT
ACTED SOUTH SUDAN

CONSULTANT
LADDER FOR ENGINEERING AND GENERAL INVESTMENT CO.LTD

PROJECT
FRUIT PROCESSING UNIT

LOCATION
MARIDI, MARIDI COUNTY, WESTEQUATORIA, RSS

DRAWING TITLE
RC Frame layout, Elevations and Sections

DESIGN & DRAWING BY. _____ Date _____
LADDER ENGINEERING

CHECKED & APPROVED BY _____ Date _____

Scales
AS SHOWN

Layout ID. _____ Revision _____
A02-2

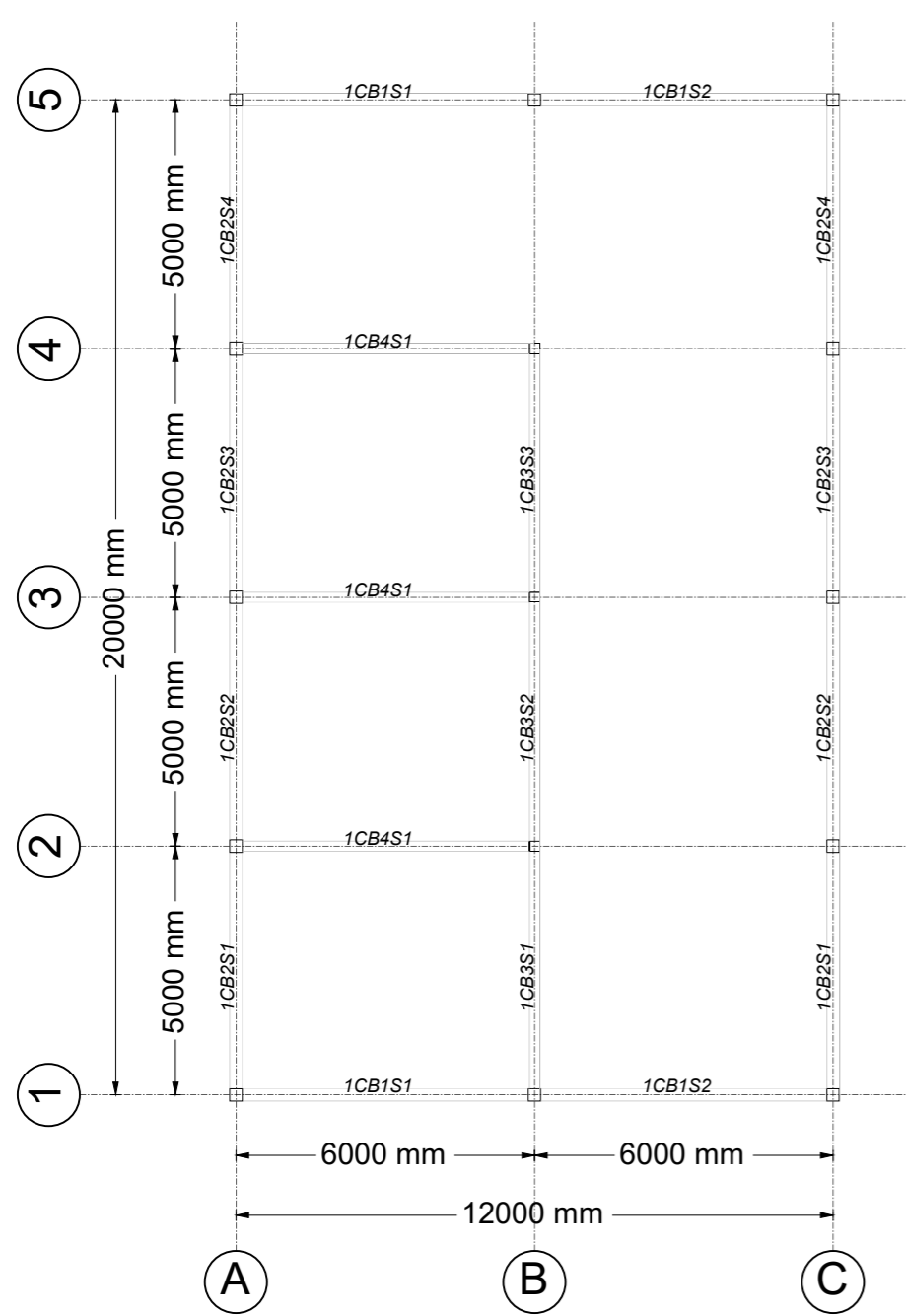

Concrete Beam Layout - Story1 (EL. 3200 mm)
(Scale = 1:75)

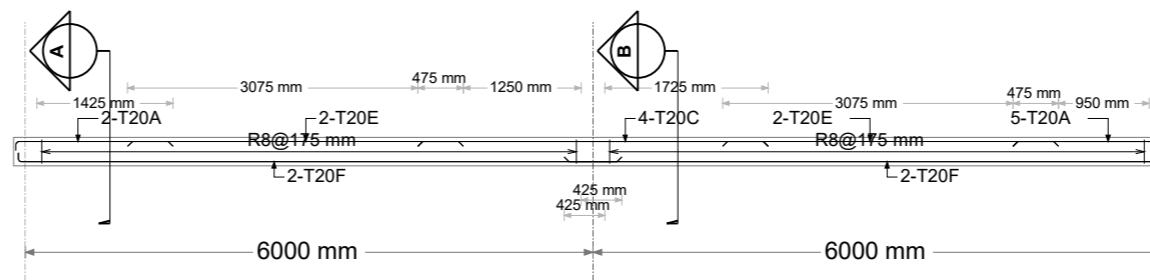

1CB1:Elevation
(Scale = 1:40)

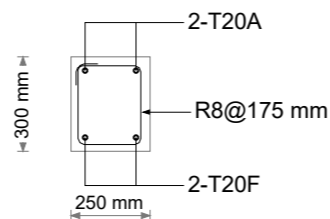

1CB1:Section A
(Scale = 1:15)

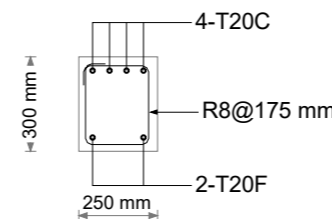

1CB1:Section B
(Scale = 1:15)

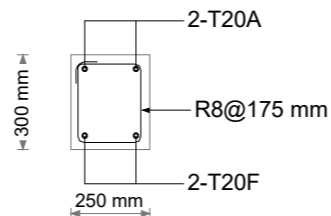

1CB2:Section A
(Scale = 1:15)

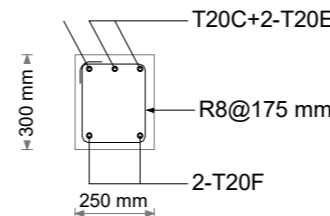

1CB2:Section B
(Scale = 1:15)

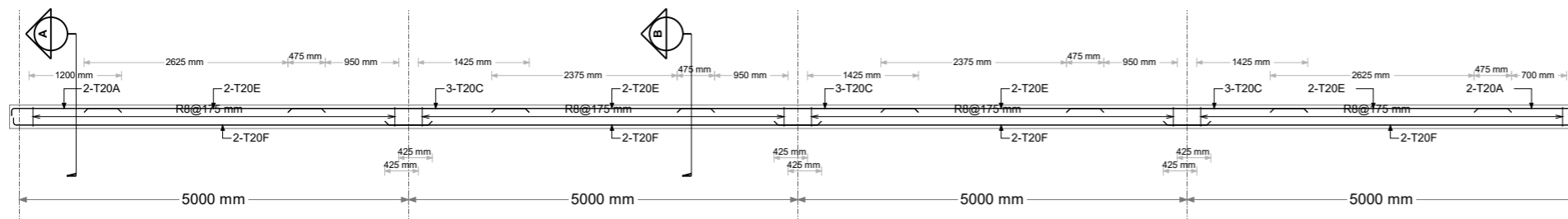

1CB2:Elevation
(Scale = 1:40)

GENERAL NOTES

- USE CONCRETE C-25 FOR COLUMNS, SLABS, BEAMS, AND FOOTING
- USE CONCRETE C-5 FOR LEAN CONCRETE
- USE 25mm CONCRETE COVER TO BEAMS, COLUMNS & SLAB
- USE 40mm CONCRETE COVER TO FOOTINGS
- USE CLASS S-400 DEFORMED REINFORCEMENT BARS REINFORCING STEEL FY=400N/MM²
- ACTUAL SOIL BEARING CAPACITY SHALL BE CHECKED BY THE SUPERVISING ENGINEER DURING ACTUAL EXCAVATION FOR FOUNDATION.
- MAXIMUM SIZE OF AGGREGATE =20mm
- FOUNDATION DEPTH SHALL BE DECIDED BY THE ENG. ON SITE
- ALL DIMENSIONS ARE IN mm BE SCALED
- THE DIMENSIONS IN DRAWINGS SHOULD NOT BE SCALED
- THIS DRAWING SHOULD READ IN CONNECTION WITH ARCHITECTURAL, SANITARY, AND ELECTRICAL

No.	Date	Description

Drawing status
STRUCTURAL DRAWING

CLIENT
ACTED SOUTH SUDAN

CONSULTANT
LADDER FOR ENGINEERING AND GENERAL INVESTMENT CO.LTD

PROJECT
FRUIT PROCESSING UNIT

LOCATION
IBBA, IBBA COUNTY, WESTEQUATORIA, RSS

DRAWING TITLE
RC Frame layout, Elevations and Sections

DESIGN & DRAWING BY. _____ Date _____

LADDER ENGINEERING

CHECKED & APPROVED BY _____ Date _____

Scales
AS SHOWN

Layout ID. _____ Revision _____

A02-3

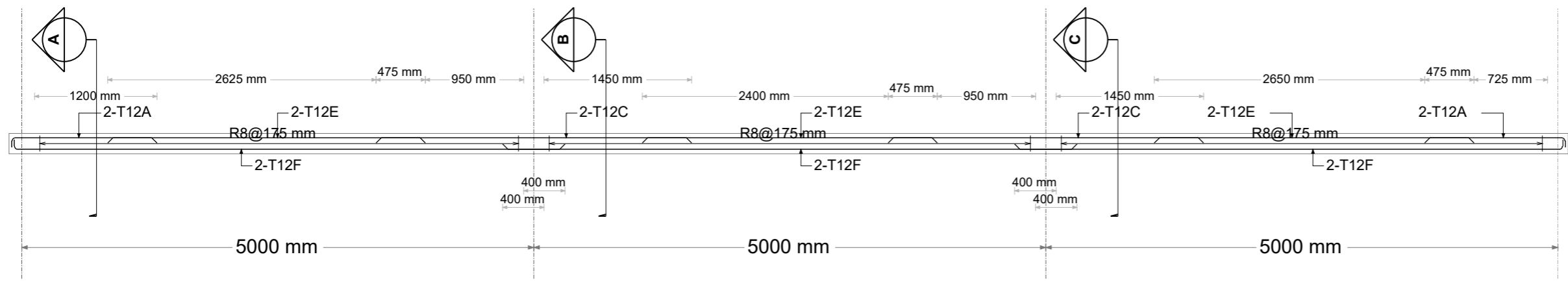

1CB3:Elevation
(Scale = 1:25)

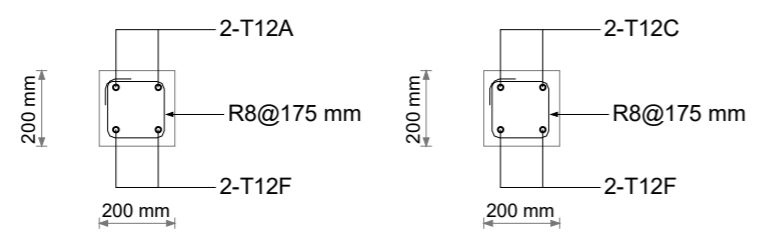

1CB3:Section A
(Scale = 1:10)

1CB3:Section B
(Scale = 1:10)

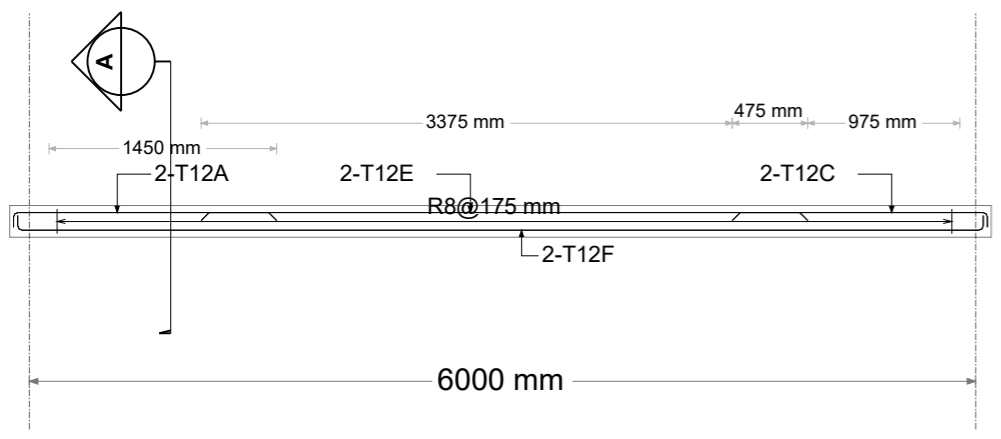

1CB4:Elevation
(Scale = 1:25)

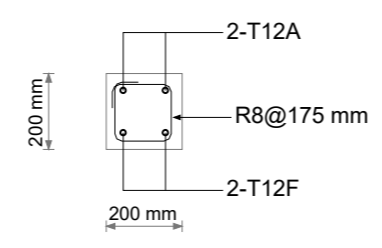

1CB4:Section A
(Scale = 1:10)

GENERAL NOTES

- USE CONCRETE C-25 FOR COLUMNS, SLABS, BEAMS, AND FOOTING
- USE CONCRETE C-5 FOR LEAN CONCRETE
- USE 25mm CONCRETE COVER TO BEAMS, COLUMNS & SLAB
- USE 40mm CONCRETE COVER TO FOOTINGS
- USE CLASS S-400 DEFORMED REINFORCEMENT BARS REINFORCING STEEL FY=400N/MM2
- ACTUAL SOIL BEARING CAPACITY SHALL BE CHECKED BY THE SUPERVISING ENGINEER DURING ACTUAL EXCAVATION FOR FOUNDATION.
- MAXIMUM SIZE OF AGGREGATE =20mm
- FOUNDATION DEPTH SHALL BE DECIDED BY THE ENG. ON SITE
- ALL DIMENSIONS ARE IN mm
- THE DIMENSIONS IN DRAWINGS SHOULD NOT BE SCALED
- THIS DRAWING SHOULD READ IN CONNECTION WITH ARCHITECTURAL, SANITARY, AND ELECTRICAL

No.	Date	Description

Drawing status
STRUCTURAL DRAWING

CLIENT
ACTED SOUTH SUDAN

CONSULTANT
LADDER FOR ENGINEERING AND GENERAL INVESTMENT CO.LTD

PROJECT
FRUIT PROCESSING UNIT

LOCATION
MARIDI, MARIDI COUNTY, WESTEQUATORIA, RSS

DRAWING TITLE
RC Frame layout, Elevations and Sections

DESIGN & DRAWING BY. _____ Date _____
LADDER ENGINEERING

CHECKED & APPROVED BY _____ Date _____

Scales
AS SHOWN

Layout ID. _____ Revision _____
A02-4

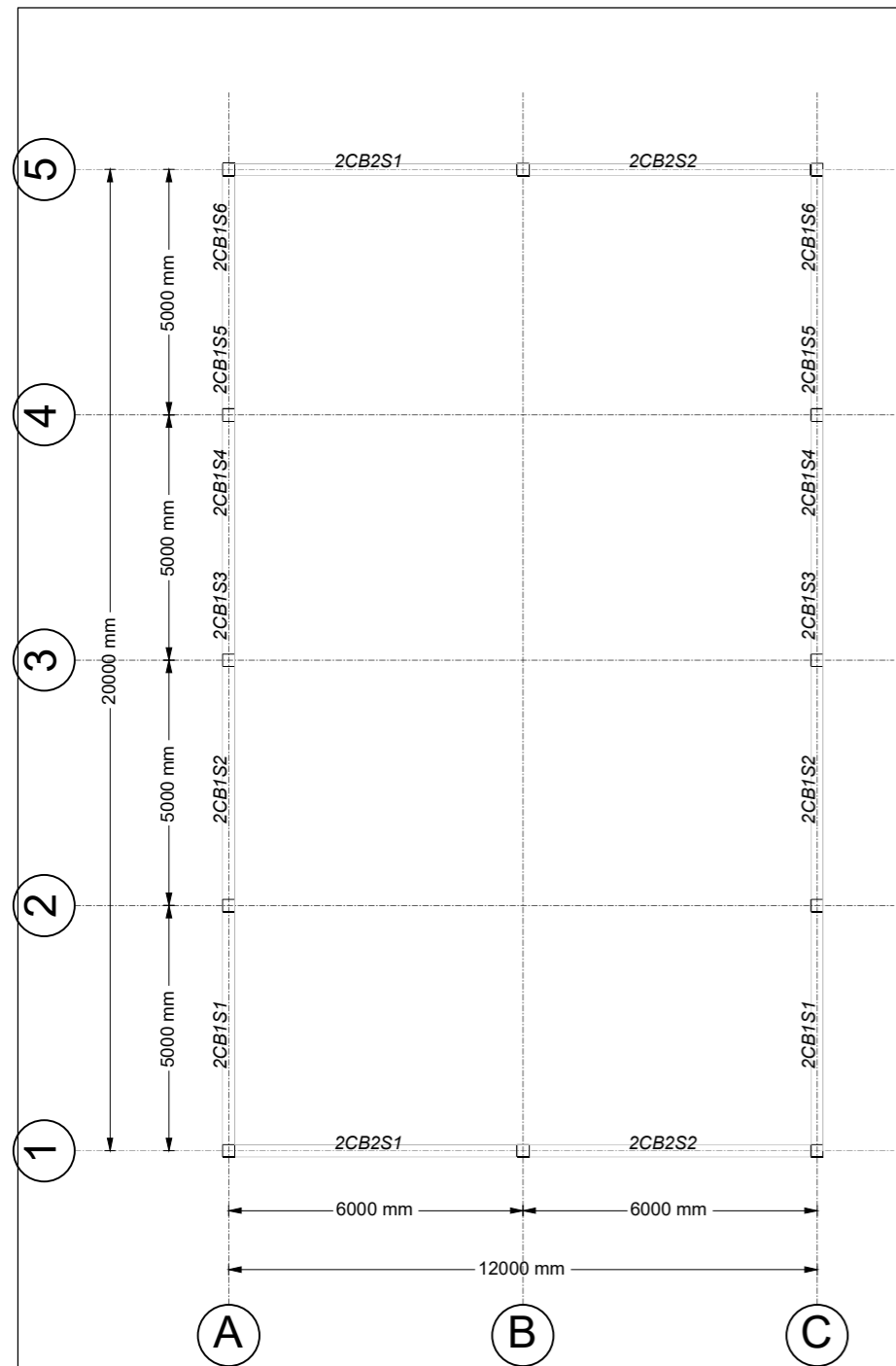

Concrete Beam Layout - Story2 (EL. 6000 mm)
(Scale = 1:75)

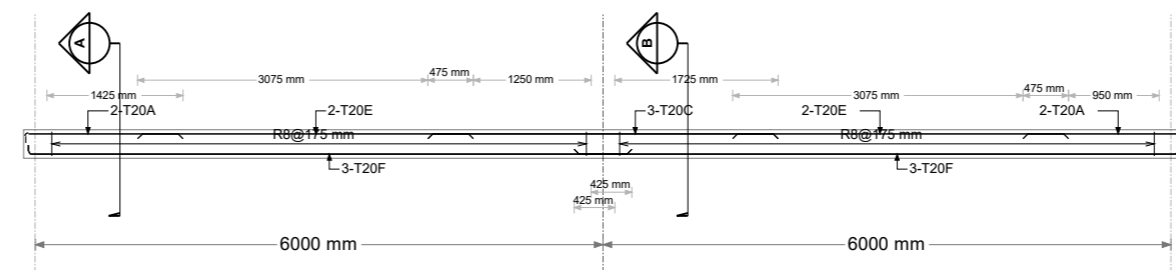

2CB2:Elevation
(Scale = 1:40)

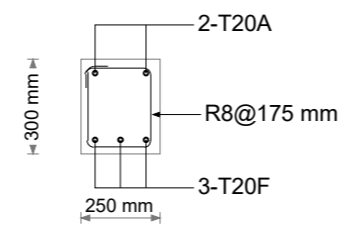

2CB2:Section A
(Scale = 1:15)

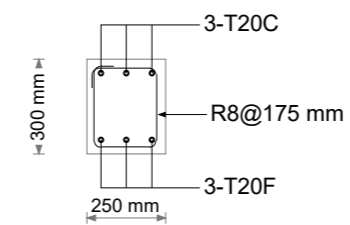

2CB2:Section B
(Scale = 1:15)

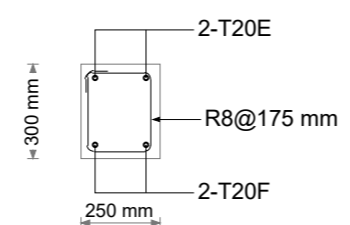

2CB1:Section B
(Scale = 1:15)

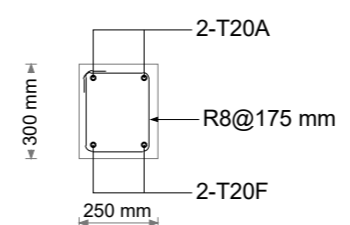

2CB1:Section A
(Scale = 1:15)

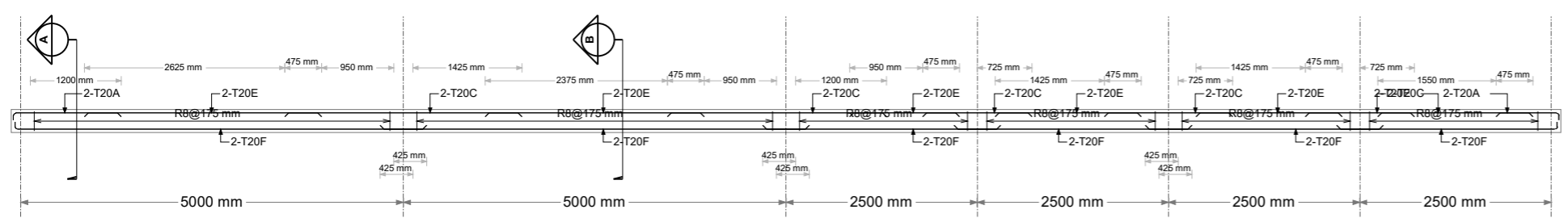

2CB1:Elevation
(Scale = 1:40)

GENERAL NOTES

- USE CONCRETE C-25 FOR COLUMNS, SLABS, BEAMS, AND FOOTING
- USE CONCRETE C-5 FOR LEAN CONCRETE
- USE 25mm CONCRETE COVER TO BEAMS, COLUMNS & SLAB
- USE 40mm CONCRETE COVER TO FOOTINGS
- USE CLASS 5-400 DEFORMED REINFORCEMENT BARS REINFORCING STEEL FY=400N/MM2
- ACTUAL SOIL BEARING CAPACITY SHALL BE CHECKED BY THE SUPERVISING ENGINEER DURING ACTUAL EXCAVATION FOR FOUNDATION.
- MAXIMUM SIZE OF AGGREGATE = 20mm
- FOUNDATION DEPTH SHALL BE DECIDED BY THE ENG. ON SITE
- ALL DIMENSIONS ARE IN mm
- BE SCALED
- THE DIMENSIONS IN DRAWINGS SHOULD NOT BE SCALED
- THIS DRAWING SHOULD READ IN CONNECTION WITH ARCHITECTURAL, SANITARY, AND ELECTRICAL

No.	Date	Description

Drawing status
STRUCTURAL DRAWING

CLIENT
ACTED SOUTH SUDAN

CONSULTANT
LADDER FOR ENGINEERING AND GENERAL INVESTMENT CO.LTD

PROJECT
FRUIT PROCESSING UNIT

LOCATION
MARIDI, MARIDI COUNTY, WESTEQUATORIA, RSS

DRAWING TITLE
RC Frame layout, Elevations and Sections

DESIGN & DRAWING BY. _____ Date _____

LADDER ENGINEERING

CHECKED & APPROVED BY _____ Date _____

Scales
AS SHOWN

Layout ID. **A02-5** Revision _____

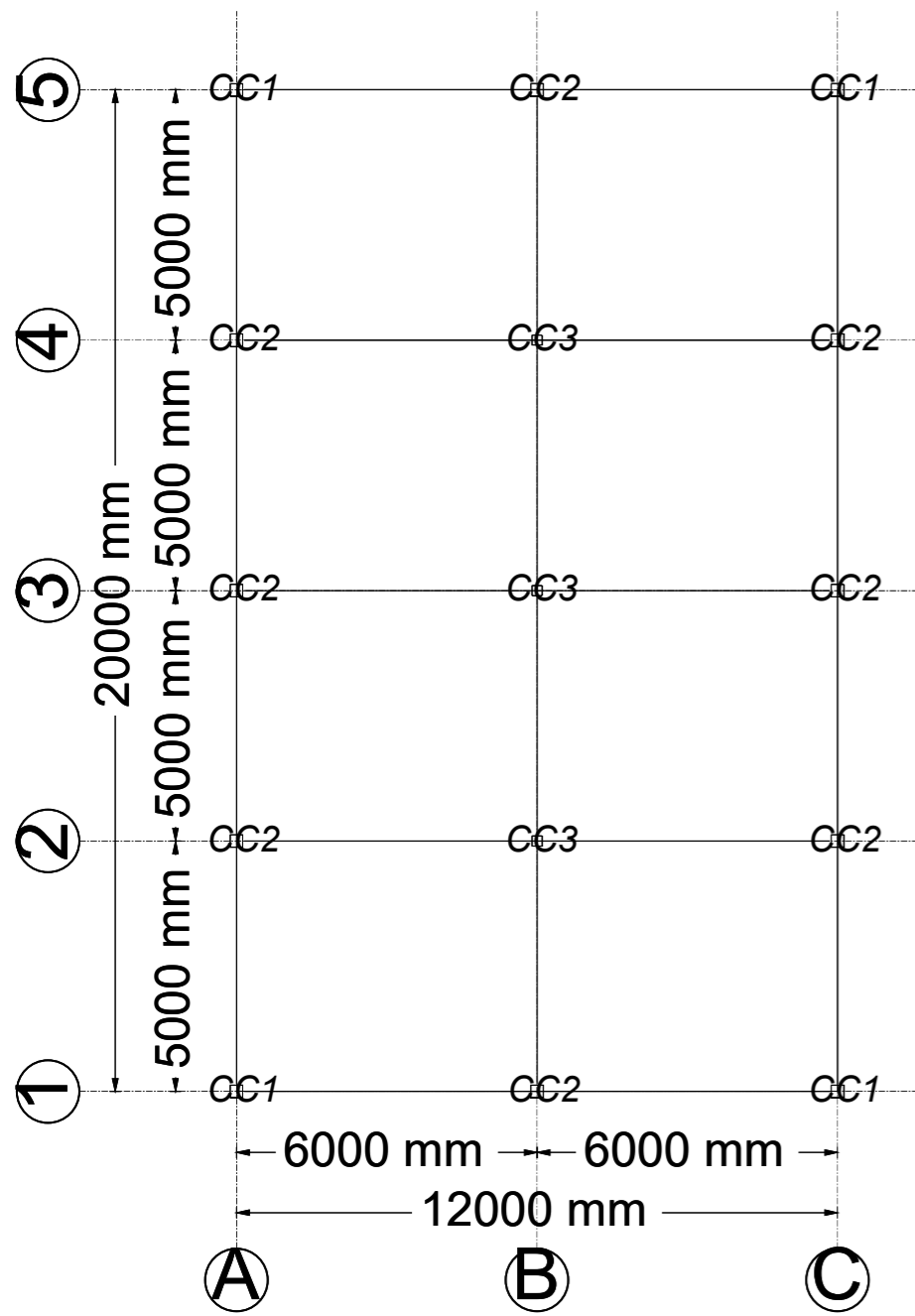

Concrete Column Layout - Base (EL. 0 mm)
(Scale = 1:75)

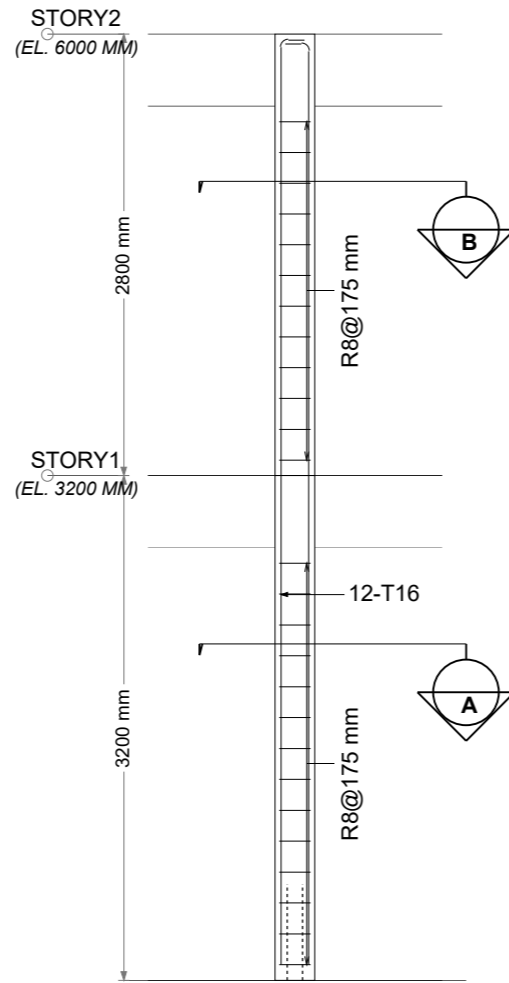

CC1:Elevation
(Scale = 1:25)

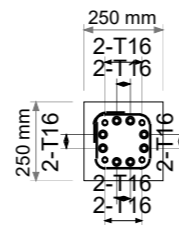

CC1:Section B
(Scale = 1:15)

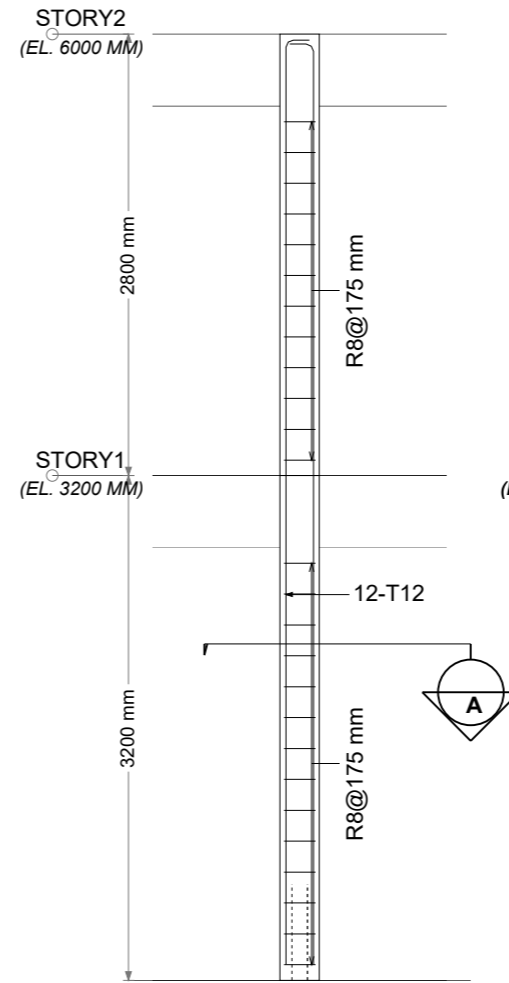

CC2:Elevation
(Scale = 1:25)

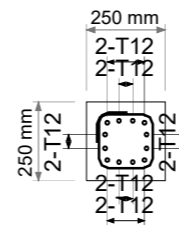

CC2:Section A
(Scale = 1:15)

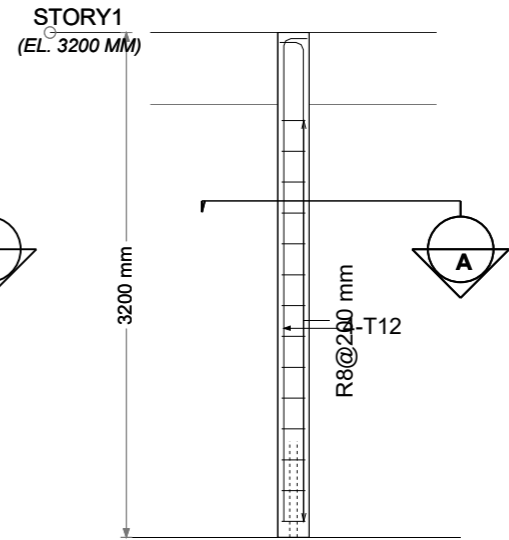

CC3:Elevation
(Scale = 1:25)

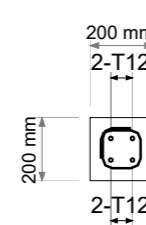

CC3:Section A
(Scale = 1:15)

GENERAL NOTES

- USE CONCRETE C-25 FOR COLUMNS, SLABS, BEAMS, AND FOOTING
- USE CONCRETE C-5 FOR LEAN CONCRETE
- USE 25mm CONCRETE COVER TO BEAMS, COLUMNS & SLAB
- USE 40mm CONCRETE COVER TO FOOTINGS
- USE CLASS S-400 DEFORMED REINFORCEMENT BARS REINFORCING STEEL FY=400N/MM²
- ACTUAL SOIL BEARING CAPACITY SHALL BE CHECKED BY THE SUPERVISING ENGINEER DURING ACTUAL EXCAVATION FOR FOUNDATION.
- MAXIMUM SIZE OF AGGREGATE =20mm
- FOUNDATION DEPTH SHALL BE DECIDED BY THE ENG. ON SITE
- ALL DIMENSIONS ARE IN mm
- BE SCALED
- THE DIMENSIONS IN DRAWINGS SHOULD NOT
- THIS DRAWING SHOULD READ IN CONNECTION WITH ARCHITECTURAL, SANITARY, AND ELECTRICAL

No.	Date	Description

Drawing status
STRUCTURAL DRAWING

CLIENT
ACTED SOUTH SUDAN

CONSULTANT
LADDER FOR ENGINEERING AND GENERAL INVESTMENT CO.LTD

PROJECT
FRUIT PROCESSING UNIT

LOCATION
MARIDI, MARIDI COUNTY, WESTEQUATORIA, RSS

DRAWING TITLE
RC Frame layout, Elevations and Sections

DESIGN & DRAWING BY. _____ Date _____
LADDER ENGINEERING

CHECKED & APPROVED BY _____ Date _____

Scales
AS SHOWN

Layout ID. **A02-6** Revision _____

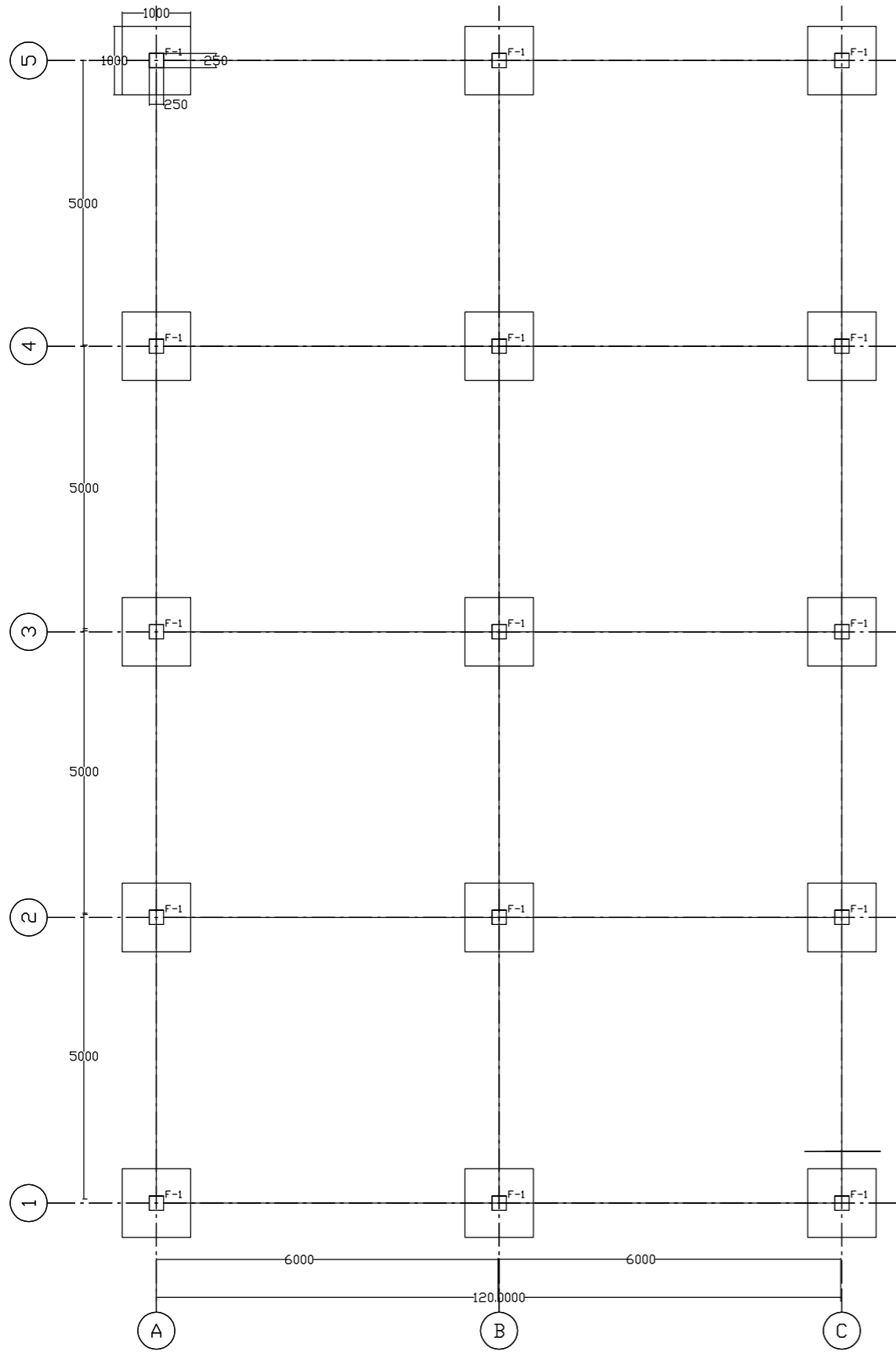

Isolated Footing Layout - Base (EL. -1200mm)
(Scale 1:100)

2

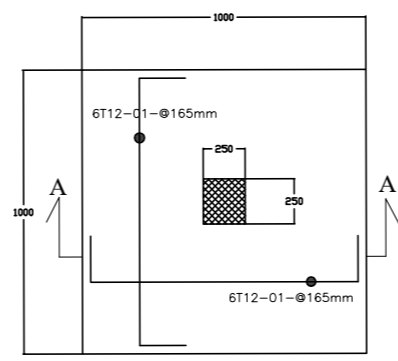

ISOLATED FOOTING F-1 (15- PCS)
SCALE 1 : 25

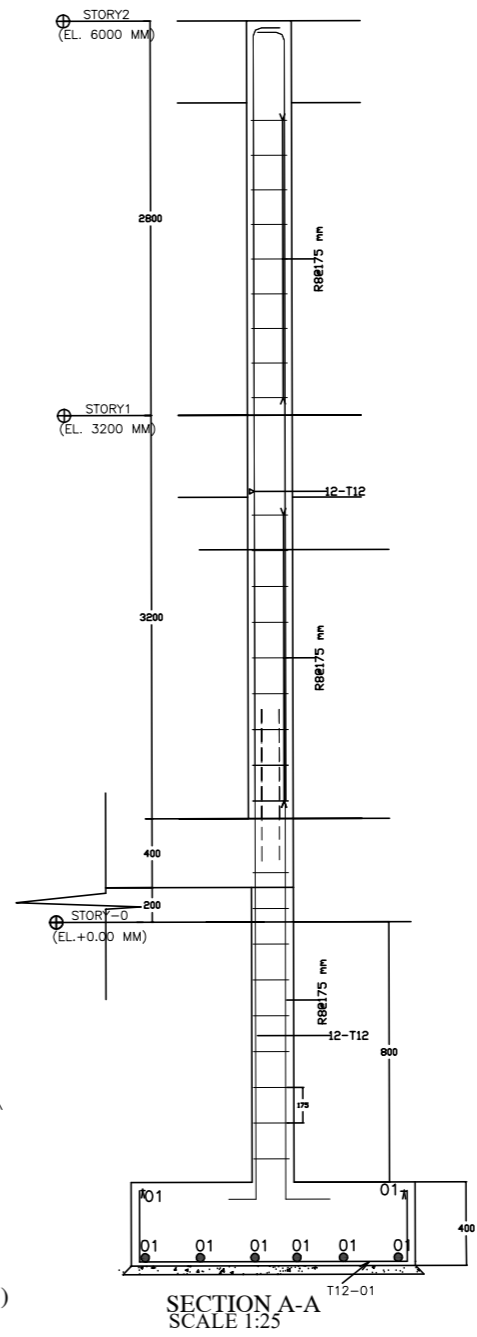

SECTION A-A
SCALE 1:25

GENERAL NOTES

- USE CONCRETE C-25 FOR COLUMNS, SLABS, BEAMS, AND FOOTING
- USE CONCRETE C-5 FOR LEAN CONCRETE
- USE 25mm CONCRETE COVER TO BEAMS, COLUMNS & SLAB
- USE 40mm CONCRETE COVER TO FOOTINGS
- USE CLASS S-400 DEFORMED REINFORCEMENT BARS
- REINFORCING STEEL $F_y = 400N/MM^2$
- ACTUAL SOIL BEARING CAPACITY SHALL BE CHECKED BY THE SUPERVISING ENGINEER DURING ACTUAL EXCAVATION FOR FOUNDATION.
- MAXIMUM SIZE OF AGGREGATE = 20mm
- FOUNDATION DEPTH SHALL BE DECIDED BY THE ENG. ON SITE
- ALL DIMENSIONS ARE IN mm
- BE SCALED
- THE DIMENSIONS IN DRAWINGS SHOULD NOT
- THIS DRAWING SHOULD READ IN CONNECTION WITH ARCHITECTURAL, SANITARY, AND ELECTRICAL

No.	Date	Description

Drawing status
STRUCTURAL DRAWING

CLIENT
ACTED SOUTH SUDAN

CONSULTANT
LADDER FOR ENGINEERING AND GENERAL INVESTMENT CO.LTD

PROJECT
FRUIT PROCESSING UNIT

LOCATION
MARIDI, MARIDI COUNTY, WESTEQUATORIA, RSS

DRAWING TITLE
RC Frame layout, Elevations and Sections

DESIGN & DRAWING BY. _____ Date _____
LADDER ENGINEERING

CHECKED & APPROVED BY _____ Date _____

Scales
AS SHOWN

Layout ID. _____ Revision _____
A02-7