

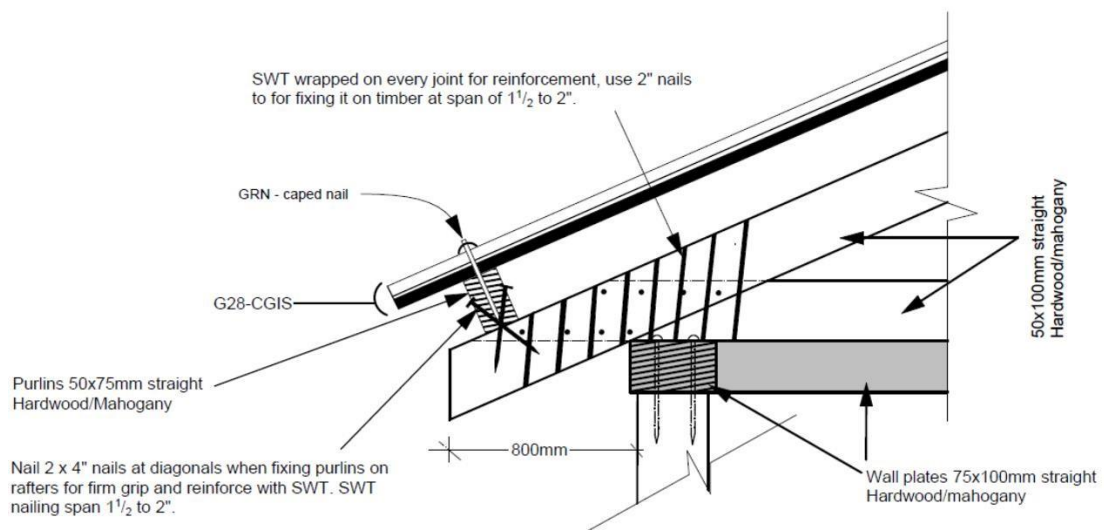

3 - Truss details:

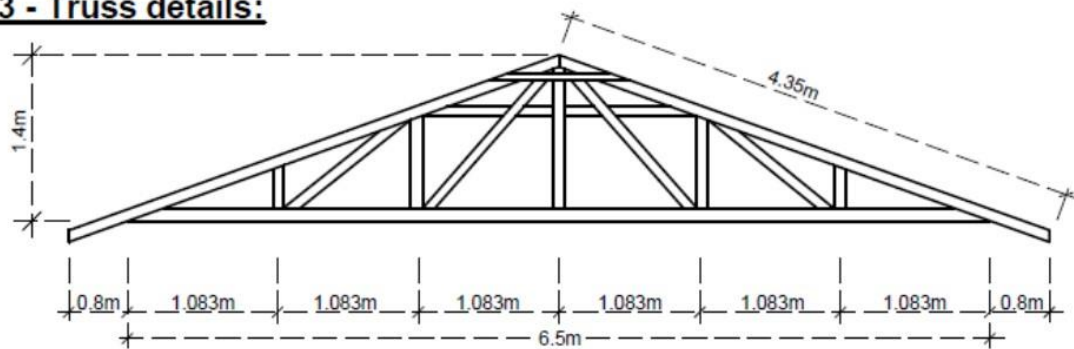

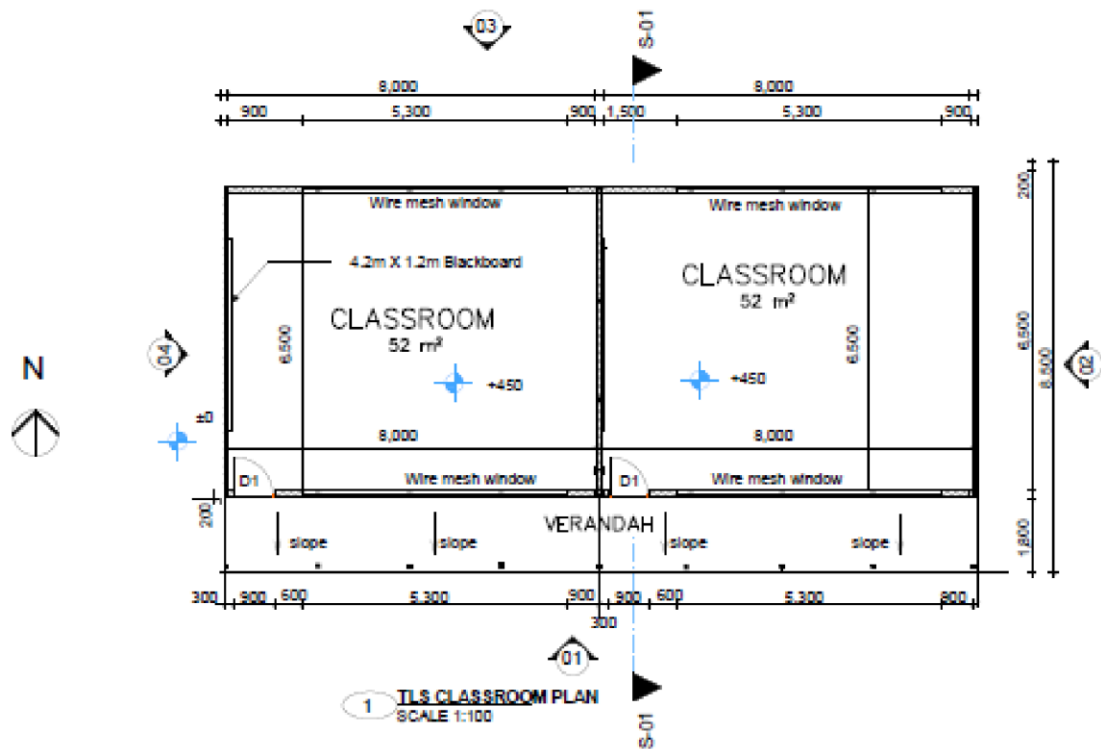

Adequate learning spaces are conducive to learning. Safe structures minimise risk to children

