

**GENERAL NOTES**

- USE CONCRETE C-25 FOR COLUMNS, SLABS, BEAMS, AND FOOTING
- USE CONCRETE C-5 FOR LEAN CONCRETE
- USE 25mm CONCRETE COVER TO BEAMS, COLUMNS & SLAB
- USE 40mm CONCRETE COVER TO FOOTINGS
- USE CLASS S-400 DEFORMED REINFORCEMENT BARS
- REINFORCING STEEL  $F_y = 400N/MM^2$
- ACTUAL SOIL BEARING CAPACITY SHALL BE CHECKED BY THE SUPERVISING ENGINEER DURING ACTUAL EXCAVATION FOR FOUNDATION.
- MAXIMUM SIZE OF AGGREGATE = 20mm
- FOUNDATION DEPTH SHALL BE DECIDED BY THE ENG. ON SITE
- ALL DIMENSIONS ARE IN mm
- BE SCALED
- THE DIMENSIONS IN DRAWINGS SHOULD NOT
- THIS DRAWING SHOULD READ IN CONNECTION WITH ARCHITECTURAL, SANITARY, AND ELECTRICAL

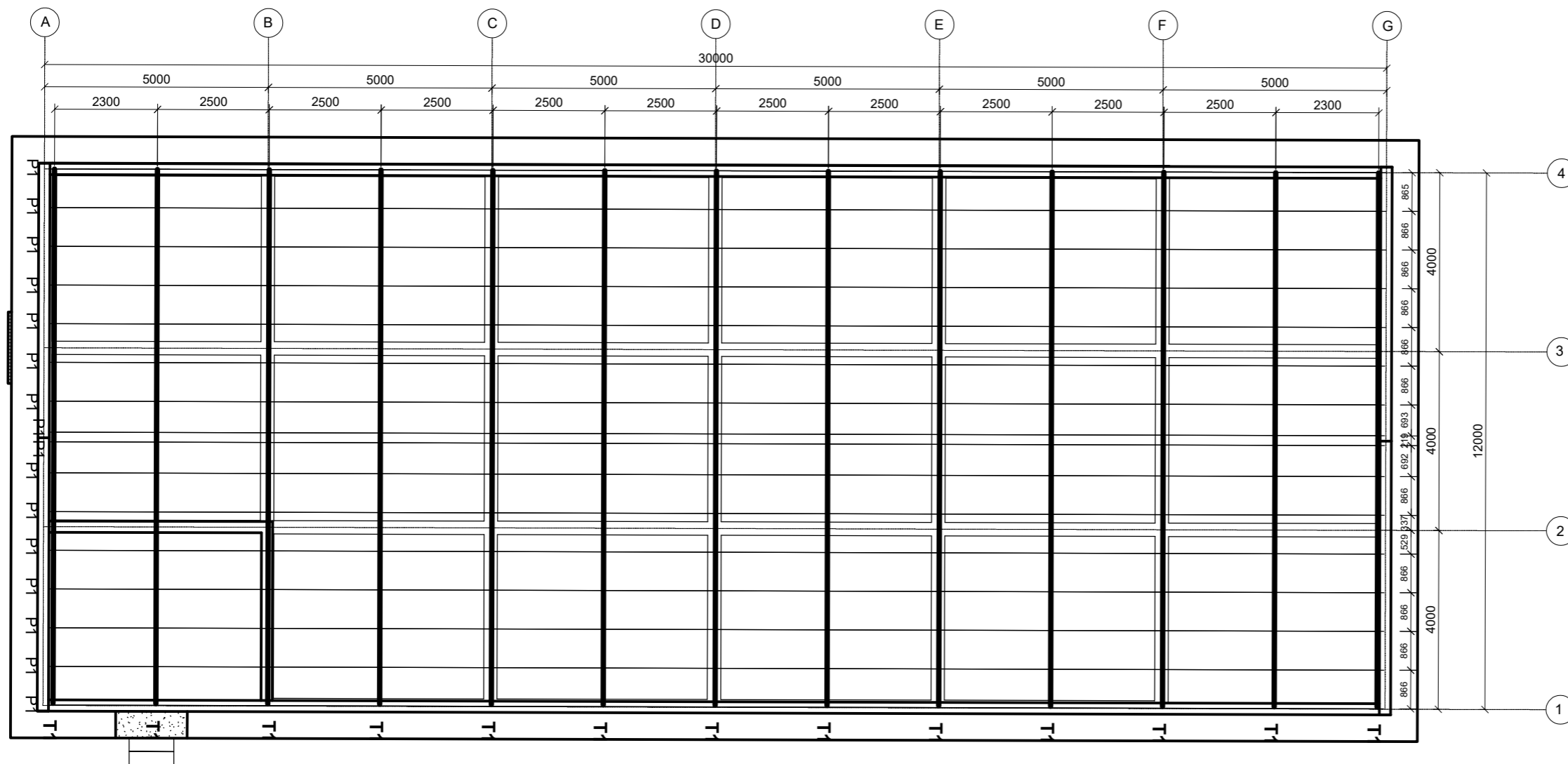

ROOF LAYOUT PLAN  
SCALE 1:100

No.	Date	Description

Drawing status		<b>STRUCTURAL DRAWING</b>
CLIENT		<b>ACTED SOUTH SUDAN</b>
CONSULTANT		<b>LADDER FOR ENGINEERING AND GENERAL INVESTMENT CO.LTD</b>
PROJECT		<b>1500 MT WAREHOUSE</b>
LOCATION		<b>NAMRABIA, IBBA COUNTY, WESTERN EQUATORIAL STATE, RSS</b>
DRAWING TITLE		<b>ROOF LAYOUT PLAN</b>
DESIGN & DRAWING BY.	Date	
		<b>LADDER ENGINEERING</b>
CHECKED & APPROVED BY	Date	
Scales		<b>AS SHOWN</b>
Layout ID.	Revision	
		<b>A01-1</b>

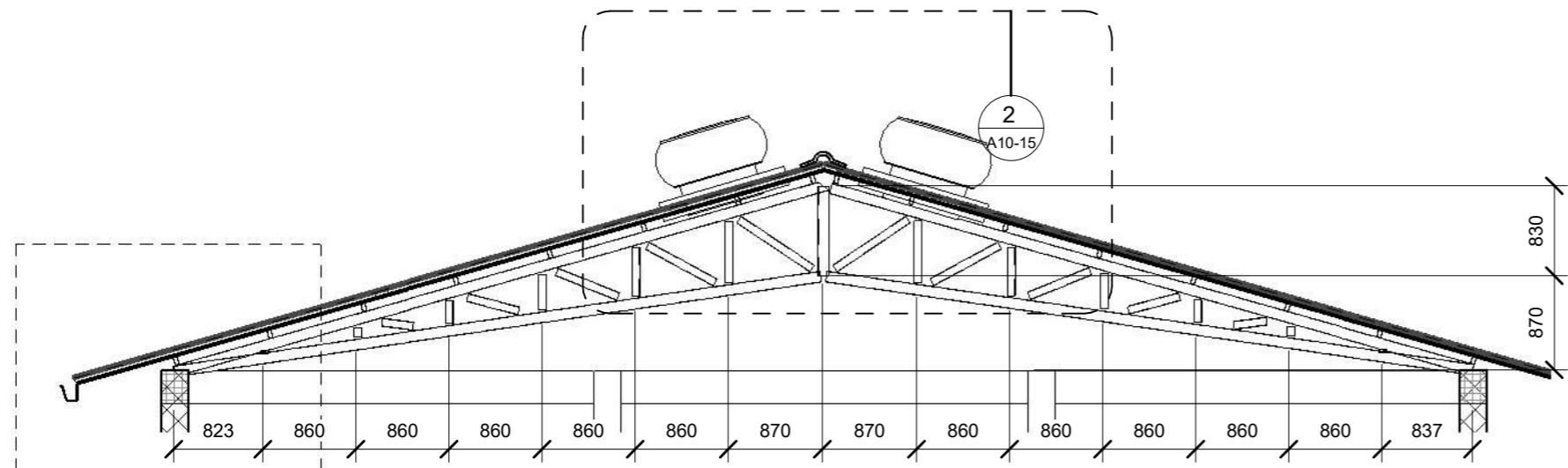

**ROOF TRUSS DETAILS**

SCALE 1:50

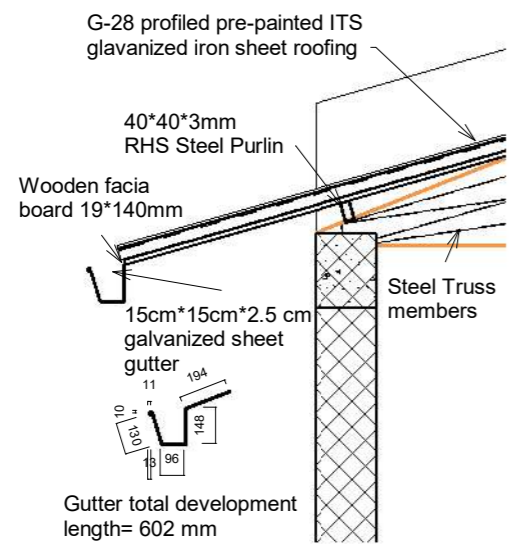

**Gutter Details**

1 : 25

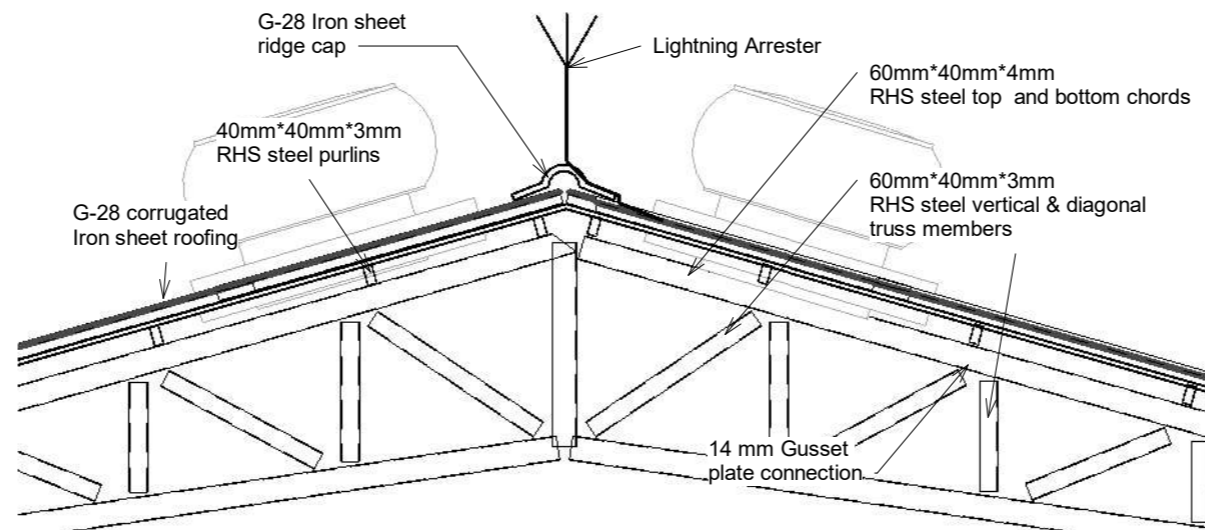

**ROOF RIDGE DETAILS**

SCALE 1:25

**GENERAL NOTES**

- USE CONCRETE C-25 FOR COLUMNS, SLABS, BEAMS, AND FOOTING
- USE CONCRETE C-5 FOR LEAN CONCRETE
- USE 25mm CONCRETE COVER TO BEAMS, COLUMNS & SLAB
- USE 40mm CONCRETE COVER TO FOOTINGS
- USE CLASS S-400 DEFORMED REINFORCEMENT BARS REINFORCING STEEL F<sub>y</sub>=400N/MM<sup>2</sup>
- ACTUAL SOIL BEARING CAPACITY SHALL BE CHECKED BY THE SUPERVISING ENGINEER DURING ACTUAL EXCAVATION FOR FOUNDATION.
- MAXIMUM SIZE OF AGGREGATE =20mm
- FOUNDATION DEPTH SHALL BE DECIDED BY THE ENG. ON SITE
- ALL DIMENSIONS ARE IN mm
- THE DIMENSIONS IN DRAWINGS SHOULD NOT BE SCALED
- THIS DRAWING SHOULD READ IN CONNECTION WITH ARCHITECTURAL, SANITARY, AND ELECTRICAL

No.	Date	Description
-----	------	-------------

Drawing status  
**STRUCTURAL DRAWING**

CLIENT  
**ACTED SOUTH SUDAN**

CONSULTANT  
**LADDER FOR ENGINEERING AND GENERAL INVESTMENT CO.LTD**

PROJECT  
**1500 MT WAREHOUSE**

LOCATION  
**NAMRABIA, IBBA COUNTY, WESTERN EQUATORIAL STATE, RSS**

DRAWING TITLE  
**RC Frame layout, Elevations and Sections**

DESIGN & DRAWING BY. \_\_\_\_\_ Date \_\_\_\_\_  
**LADDER ENGINEERING**

CHECKED & APPROVED BY \_\_\_\_\_ Date \_\_\_\_\_

Scales  
**AS SHOWN**

Layout ID. \_\_\_\_\_ Revision \_\_\_\_\_  
**A01-2**

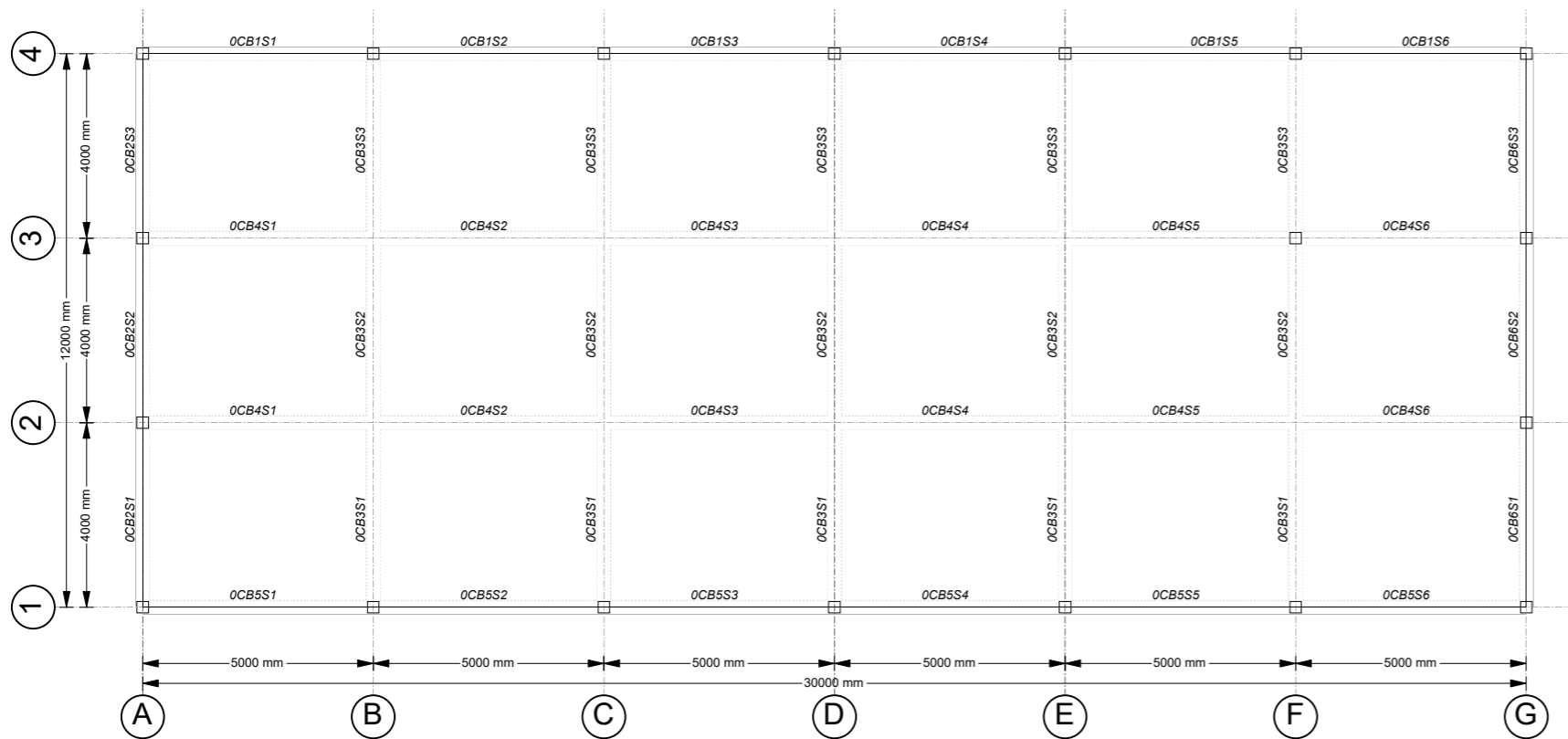

Concrete Beam Layout - Base (EL. 0 mm)  
(Scale = 1/12"=1'-0")

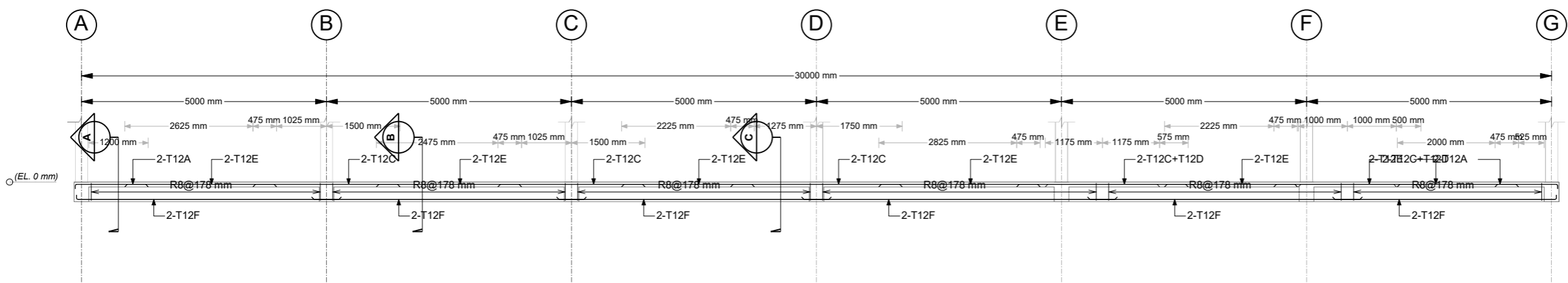

0CB1:Elevation  
(Scale = 1/8"=1'-0")

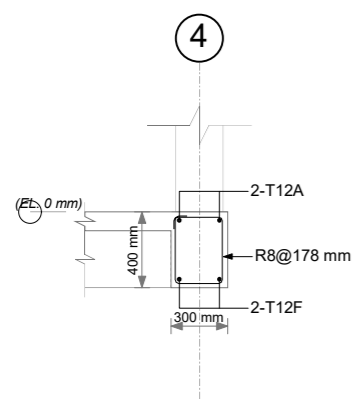

0CB1:Section A  
(Scale = 3/8"=1'-0")

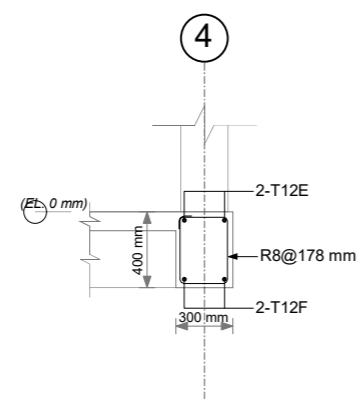

0CB1:Section B  
(Scale = 3/8"=1'-0")

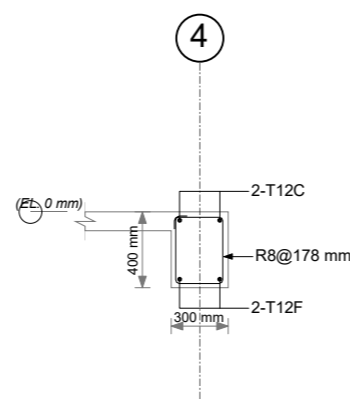

0CB1:Section C  
(Scale = 3/8"=1'-0")

**GENERAL NOTES**

- USE CONCRETE C-25 FOR COLUMNS, SLABS, BEAMS, AND FOOTING
- USE CONCRETE C-5 FOR LEAN CONCRETE
- USE 25mm CONCRETE COVER TO BEAMS, COLUMNS & SLAB
- USE 40mm CONCRETE COVER TO FOOTINGS
- USE CLASS S-400 DEFORMED REINFORCEMENT BARS REINFORCING STEEL FY=400N/MM<sup>2</sup>
- ACTUAL SOIL BEARING CAPACITY SHALL BE CHECKED BY THE SUPERVISING ENGINEER DURING ACTUAL EXCAVATION FOR FOUNDATION.
- MAXIMUM SIZE OF AGGREGATE =20mm
- FOUNDATION DEPTH SHALL BE DECIDED BY THE ENG. ON SITE
- ALL DIMENSIONS ARE IN mm
- THE DIMENSIONS IN DRAWINGS SHOULD NOT BE SCALED
- THIS DRAWING SHOULD READ IN CONNECTION WITH ARCHITECTURAL, SANITARY, AND ELECTRICAL

No.	Date	Description

Drawing status  
**STRUCTURAL DRAWING**

CLIENT  
**ACTED SOUTH SUDAN**

CONSULTANT  
**LADDER FOR ENGINEERING AND GENERAL INVESTMENT CO.LTD**

PROJECT  
**1500 MT WAREHOUSE**

LOCATION  
**NAMRABIA, IBBA COUNTY, WESTERN EQUATORIAL STATE, RSS**

DRAWING TITLE  
**RC Frame layout, Elevations and Sections**

DESIGN & DRAWING BY. \_\_\_\_\_ Date  
**LADDER ENGINEERING**

CHECKED & APPROVED BY \_\_\_\_\_ Date

Scales  
**AS SHOWN**

Layout ID. \_\_\_\_\_ Revision  
**A02-1**

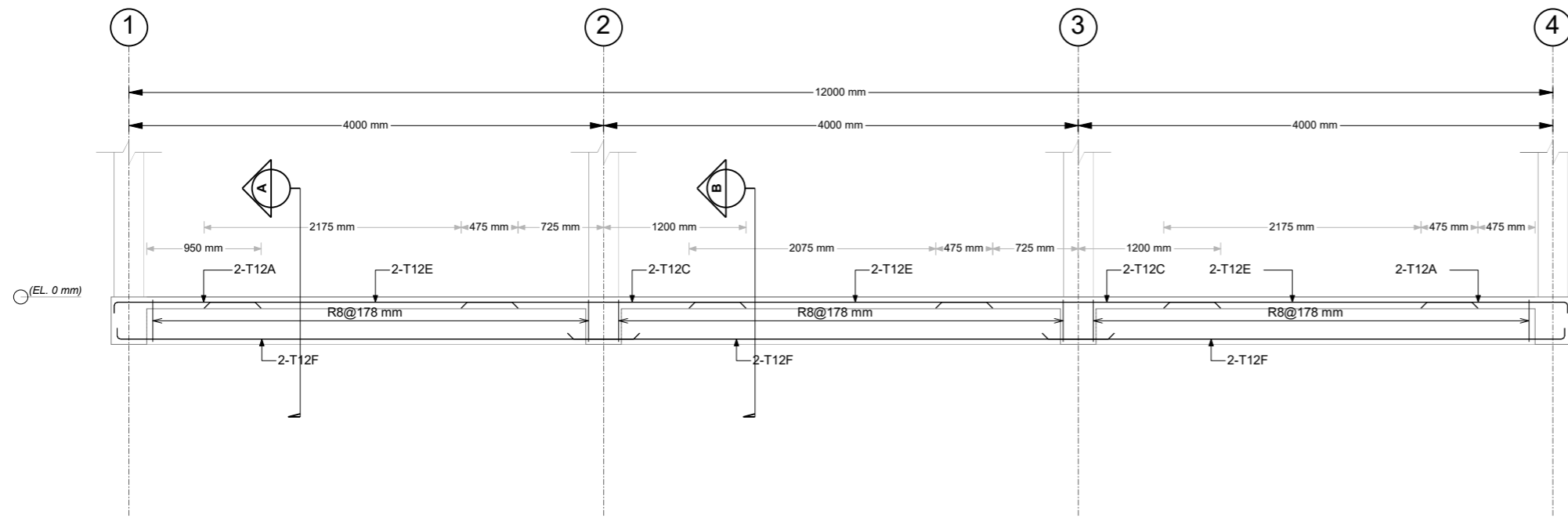

0CB2:Elevation  
(Scale = 1/4"=1'-0")

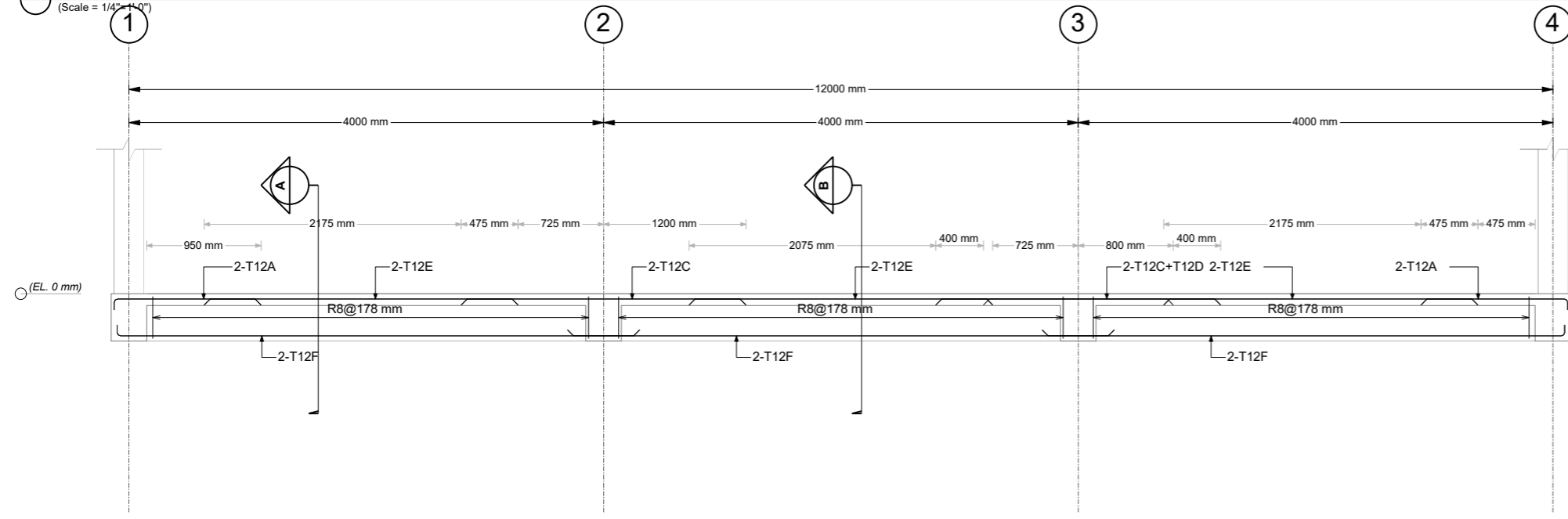

0CB3:Elevation  
(Scale = 1/4"=1'-0")

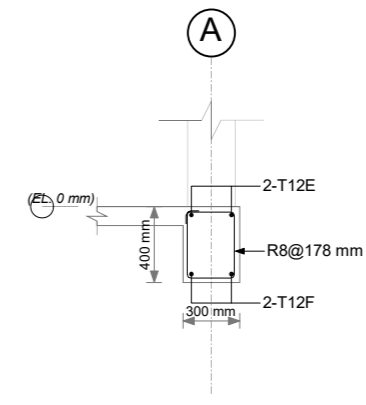

0CB2:Section A  
(Scale = 3/8"=1'-0")

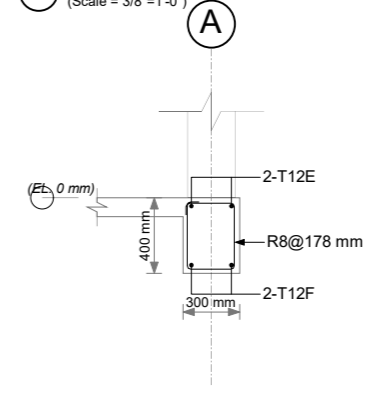

0CB2:Section B  
(Scale = 3/8"=1'-0")

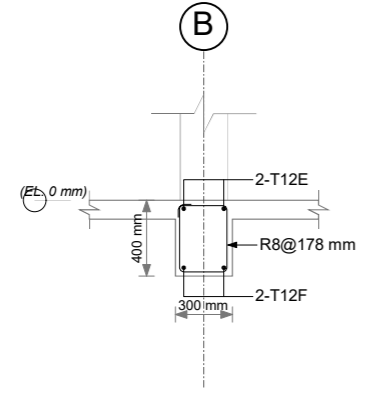

0CB3:Section A  
(Scale = 3/8"=1'-0")

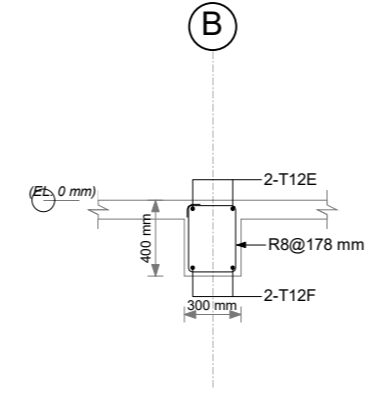

0CB3:Section B  
(Scale = 3/8"=1'-0")

**GENERAL NOTES**

- USE CONCRETE C-25 FOR COLUMNS, SLABS, BEAMS, AND FOOTING
- USE CONCRETE C-5 FOR LEAN CONCRETE
- USE 25mm CONCRETE COVER TO BEAMS, COLUMNS & SLAB
- USE 40mm CONCRETE COVER TO FOOTINGS
- USE CLASS S-400 DEFORMED REINFORCEMENT BARS
- REINFORCING STEEL FY=400N/MM2
- ACTUAL SOIL BEARING CAPACITY SHALL BE CHECKED BY THE SUPERVISING ENGINEER DURING ACTUAL EXCAVATION FOR FOUNDATION.
- MAXIMUM SIZE OF AGGREGATE =20mm
- FOUNDATION DEPTH SHALL BE DECIDED BY THE ENG. ON SITE
- ALL DIMENSIONS ARE IN mm
- BE SCALED
- THE DIMENSIONS IN DRAWINGS SHOULD NOT
- THIS DRAWING SHOULD READ IN CONNECTION WITH ARCHITECTURAL, SANITARY, AND ELECTRICAL

No.	Date	Description

Drawing status  
**STRUCTURAL DRAWING**

CLIENT  
**ACTED SOUTH SUDAN**

CONSULTANT  
**LADDER FOR ENGINEERING AND GENERAL INVESTMENT CO.LTD**

PROJECT  
**1500 MT WAREHOUSE**

LOCATION  
**NAMRABIA, IBBA COUNTY, WESTERN EQUATORIAL STATE, RSS**

DRAWING TITLE  
**RC Frame layout, Elevations and Sections**

DESIGN & DRAWING BY. \_\_\_\_\_ Date \_\_\_\_\_  
**LADDER ENGINEERING**

CHECKED & APPROVED BY \_\_\_\_\_ Date \_\_\_\_\_

Scales  
**AS SHOWN**

Layout ID. \_\_\_\_\_ Revision \_\_\_\_\_  
**A02-2**

**GENERAL NOTES**

- USE CONCRETE C-25 FOR COLUMNS, SLABS, BEAMS, AND FOOTING
- USE CONCRETE C-5 FOR LEAN CONCRETE
- USE 25mm CONCRETE COVER TO BEAMS, COLUMNS & SLAB
- USE 40mm CONCRETE COVER TO FOOTINGS
- USE CLASS S-400 DEFORMED REINFORCEMENT BARS
- REINFORCING STEEL  $F_y=400N/MM^2$
- ACTUAL SOIL BEARING CAPACITY SHALL BE CHECKED BY THE SUPERVISING ENGINEER DURING ACTUAL EXCAVATION FOR FOUNDATION.
- MAXIMUM SIZE OF AGGREGATE = 20mm
- FOUNDATION DEPTH SHALL BE DECIDED BY THE ENG. ON SITE
- ALL DIMENSIONS ARE IN mm
- BE SCALED
- THE DIMENSIONS IN DRAWINGS SHOULD NOT
- THIS DRAWING SHOULD READ IN CONNECTION WITH ARCHITECTURAL, SANITARY, AND ELECTRICAL

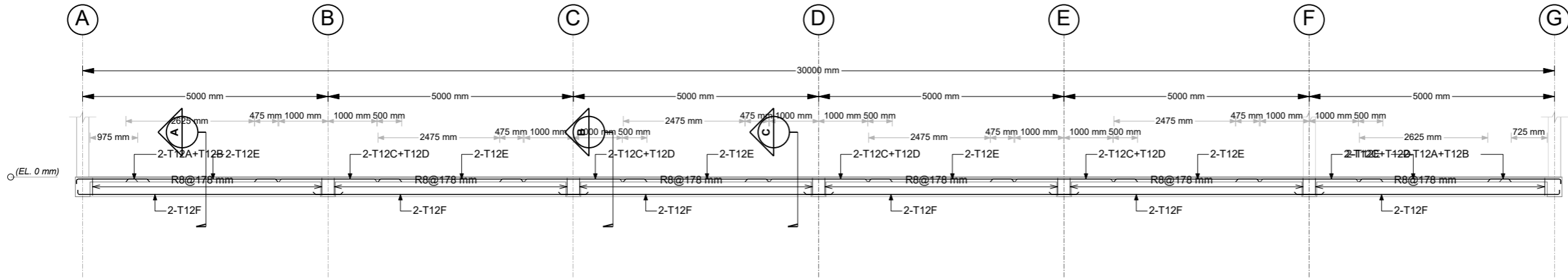

**0CB4:Elevation**  
(Scale = 1/8"=1'-0")

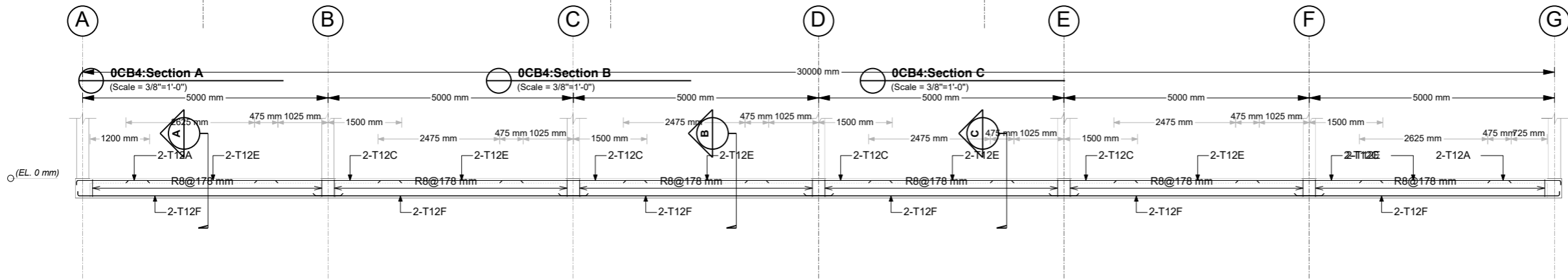
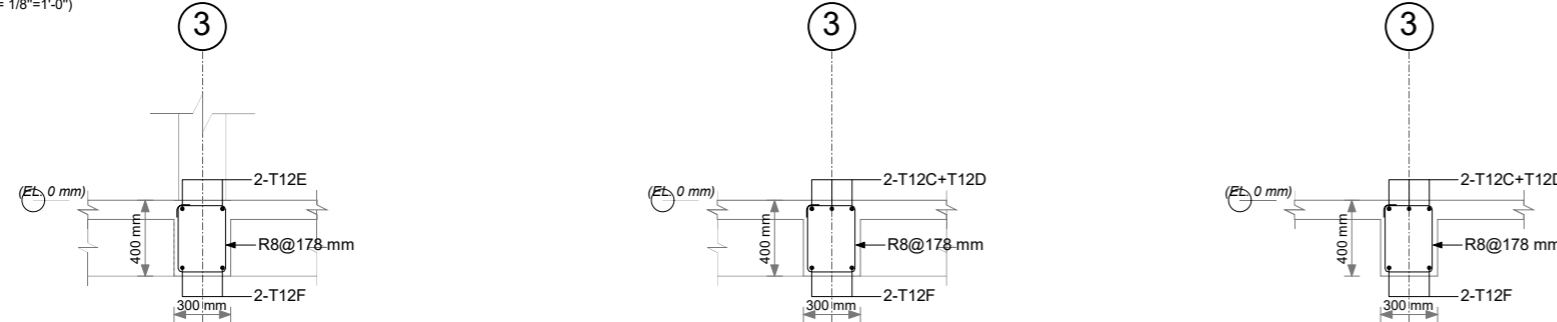

**0CB5:Elevation**  
(Scale = 1/8"=1'-0")

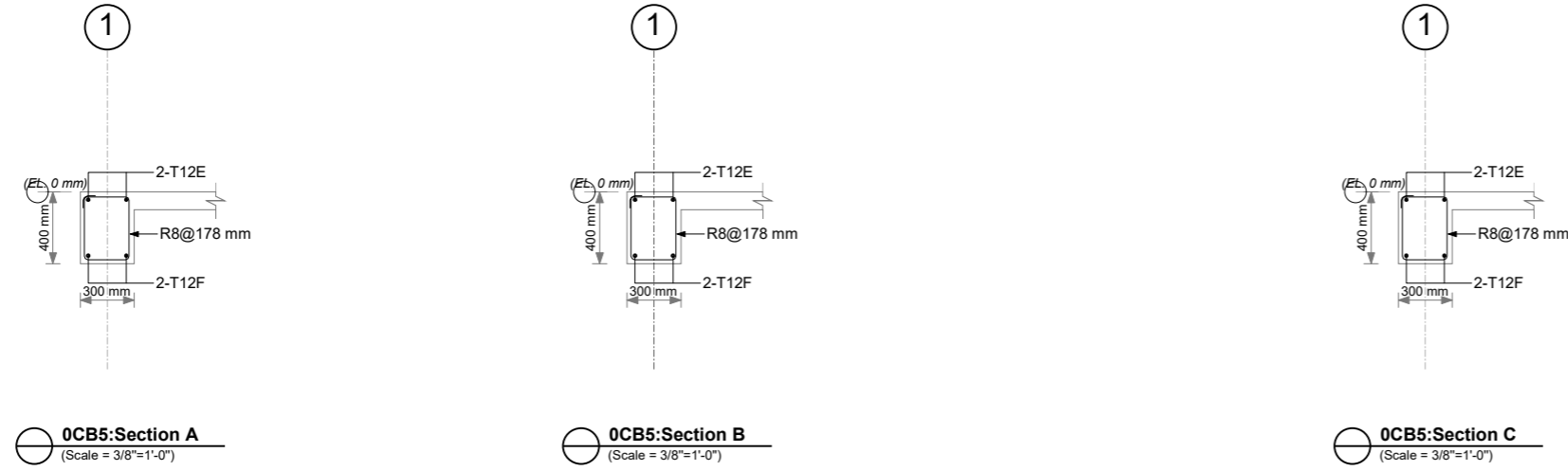

**0CB5:Section A**  
(Scale = 3/8"=1'-0")

**0CB5:Section B**  
(Scale = 3/8"=1'-0")

**0CB5:Section C**  
(Scale = 3/8"=1'-0")

No.	Date	Description

Drawing status  
**STRUCTURAL DRAWING**

CLIENT  
**ACTED SOUTH SUDAN**

CONSULTANT  
**LADDER FOR ENGINEERING AND GENERAL INVESTMENT CO.LTD**

PROJECT  
**1500 MT WAREHOUSE**

LOCATION  
**NAMRABIA, IBBA COUNTY, WESTERN EQUATORIAL STATE, RSS**

DRAWING TITLE  
**RC Frame layout, Elevations and Sections**

DESIGN & DRAWING BY. \_\_\_\_\_ Date \_\_\_\_\_  
**LADDER ENGINEERING**

CHECKED & APPROVED BY \_\_\_\_\_ Date \_\_\_\_\_

Scales  
**AS SHOWN**

Layout ID. **A02-3** Revision \_\_\_\_\_

**GENERAL NOTES**

- USE CONCRETE C-25 FOR COLUMNS, SLABS, BEAMS, AND FOOTING
- USE CONCRETE C-5 FOR LEAN CONCRETE
- USE 25mm CONCRETE COVER TO BEAMS, COLUMNS & SLAB
- USE 40mm CONCRETE COVER TO FOOTINGS
- USE CLASS S-400 DEFORMED REINFORCEMENT BARS REINFORCING STEEL  $F_y=400N/MM^2$
- ACTUAL SOIL BEARING CAPACITY SHALL BE CHECKED BY THE SUPERVISING ENGINEER DURING ACTUAL EXCAVATION FOR FOUNDATION.
- MAXIMUM SIZE OF AGGREGATE = 20mm
- FOUNDATION DEPTH SHALL BE DECIDED BY THE ENG. ON SITE
- ALL DIMENSIONS ARE IN mm
- THE DIMENSIONS IN DRAWINGS SHOULD NOT BE SCALED
- THIS DRAWING SHOULD READ IN CONNECTION WITH ARCHITECTURAL, SANITARY, AND ELECTRICAL

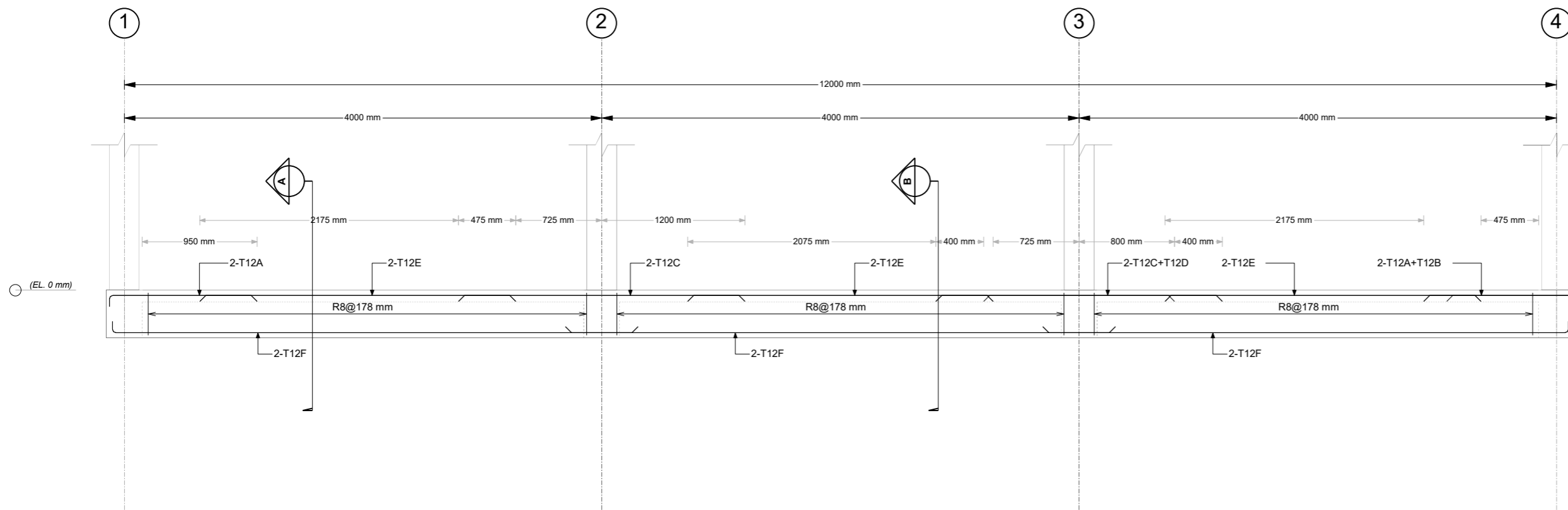

**0CB6:Elevation**  
(Scale = 3/8"=1'-0")

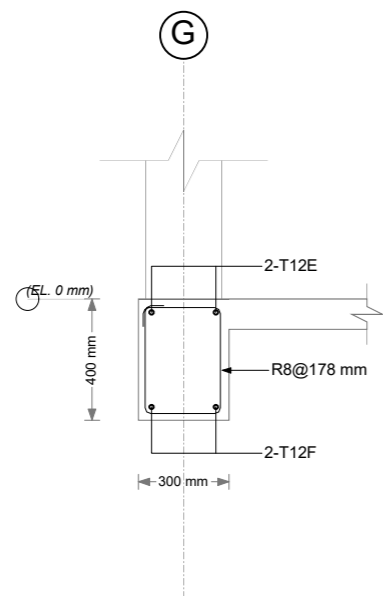

**0CB6:Section A**  
(Scale = 1/2"=1'-0")

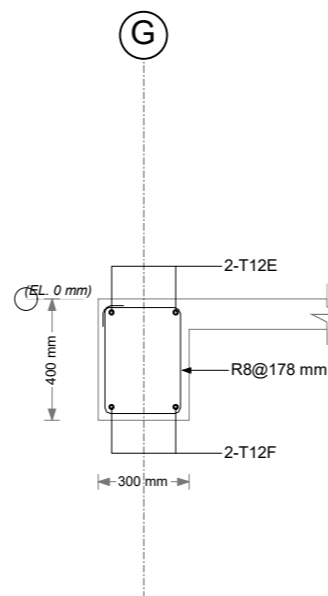

**0CB6:Section B**  
(Scale = 1/2"=1'-0")

No.	Date	Description

Drawing status  
**STRUCTURAL DRAWING**

CLIENT  
**ACTED SOUTH SUDAN**

CONSULTANT  
**LADDER FOR ENGINEERING AND GENERAL INVESTMENT CO.LTD**

PROJECT  
**1500 MT WAREHOUSE**

LOCATION  
**NAMRABIA, IBBA COUNTY, WESTERN EQUATORIAL STATE, RSS**

DRAWING TITLE  
**RC Frame layout, Elevations and Sections**

DESIGN & DRAWING BY. \_\_\_\_\_ Date \_\_\_\_\_  
**LADDER ENGINEERING**

CHECKED & APPROVED BY \_\_\_\_\_ Date \_\_\_\_\_

Scales  
**AS SHOWN**

Layout ID. \_\_\_\_\_ Revision \_\_\_\_\_  
**A02-4**

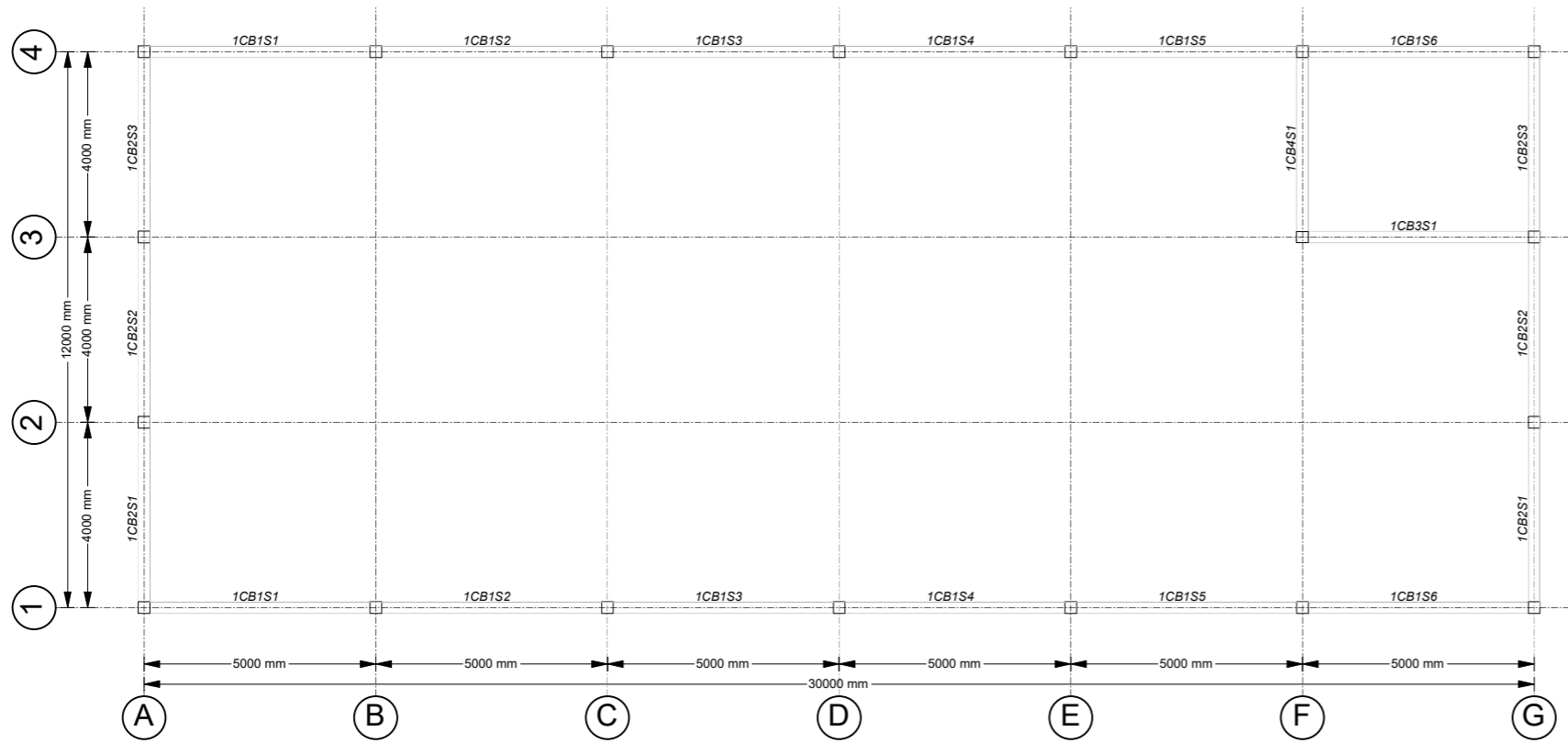

Concrete Beam Layout - Story1 (EL. 3200 mm)  
(Scale = 1/12"=1'-0")

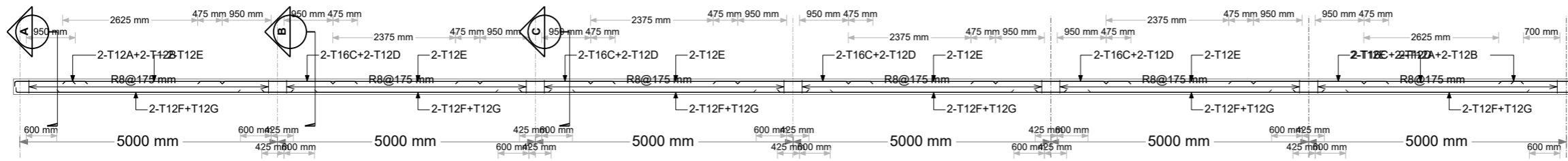

1CB1:Elevation  
(Scale = 1/8"=1'-0")

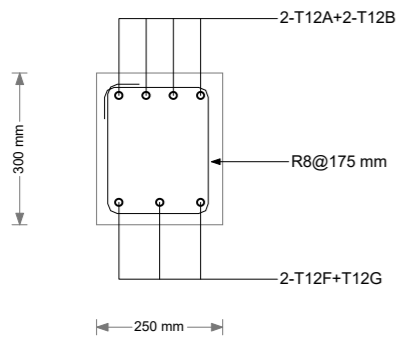

1CB1:Section A  
(Scale = 3/4"=1'-0")

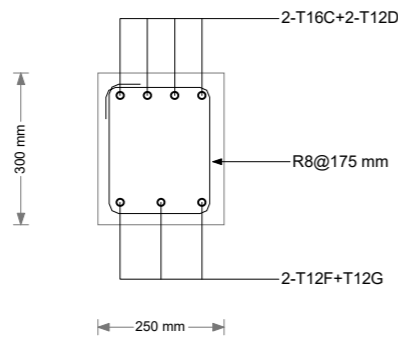

1CB1:Section B  
(Scale = 3/4"=1'-0")

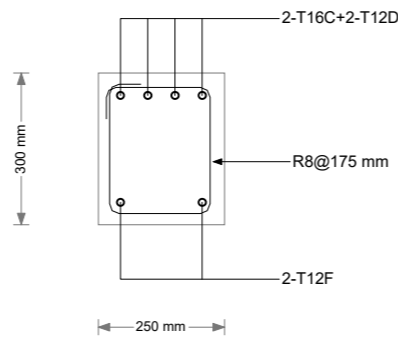

1CB1:Section C  
(Scale = 3/4"=1'-0")

**GENERAL NOTES**

- USE CONCRETE C-25 FOR COLUMNS, SLABS, BEAMS, AND FOOTING
- USE CONCRETE C-5 FOR LEAN CONCRETE
- USE 25mm CONCRETE COVER TO BEAMS, COLUMNS & SLAB
- USE 40mm CONCRETE COVER TO FOOTINGS
- USE CLASS S-400 DEFORMED REINFORCEMENT BARS
- REINFORCING STEEL  $F_y=400N/MM^2$
- ACTUAL SOIL BEARING CAPACITY SHALL BE CHECKED BY THE SUPERVISING ENGINEER DURING ACTUAL EXCAVATION FOR FOUNDATION.
- MAXIMUM SIZE OF AGGREGATE = 20mm
- FOUNDATION DEPTH SHALL BE DECIDED BY THE ENG. ON SITE
- ALL DIMENSIONS ARE IN mm
- BE SCALED
- THE DIMENSIONS IN DRAWINGS SHOULD NOT
- THIS DRAWING SHOULD READ IN CONNECTION WITH ARCHITECTURAL, SANITARY, AND ELECTRICAL

No.	Date	Description
-----	------	-------------

Drawing status  
**STRUCTURAL DRAWING**

CLIENT  
**ACTED SOUTH SUDAN**

CONSULTANT  
**LADDER FOR ENGINEERING AND GENERAL INVESTMENT CO.LTD**

PROJECT  
**1500 MT WAREHOUSE**

LOCATION  
**NAMRABIA, IBBA COUNTY, WESTERN EQUATORIAL STATE, RSS**

DRAWING TITLE  
**RC Frame layout, Elevations and Sections**

DESIGN & DRAWING BY. \_\_\_\_\_ Date \_\_\_\_\_  
**LADDER ENGINEERING**

CHECKED & APPROVED BY \_\_\_\_\_ Date \_\_\_\_\_

Scales  
**AS SHOWN**

Layout ID. **A02-5** Revision \_\_\_\_\_

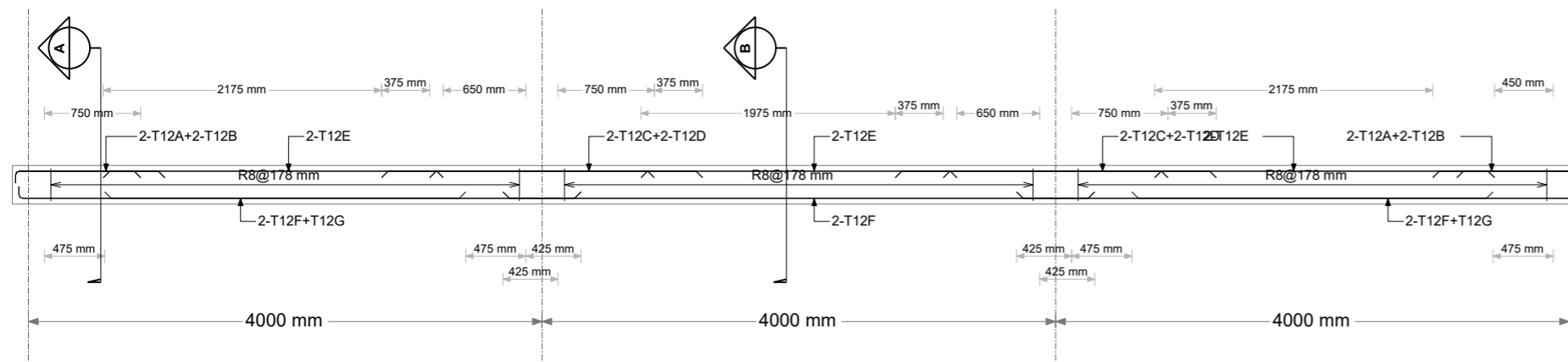

**1CB2:Elevation**  
(Scale = 1/4"=1'-0")

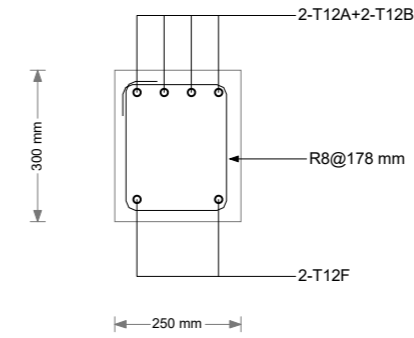

**1CB2:Section A**  
(Scale = 3/4"=1'-0")

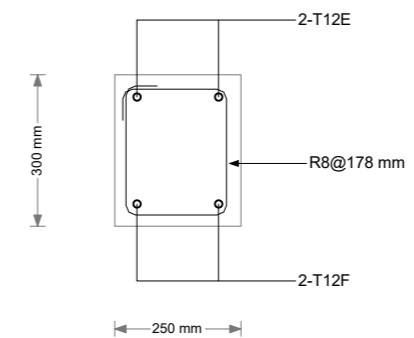

**1CB2:Section B**  
(Scale = 3/4"=1'-0")

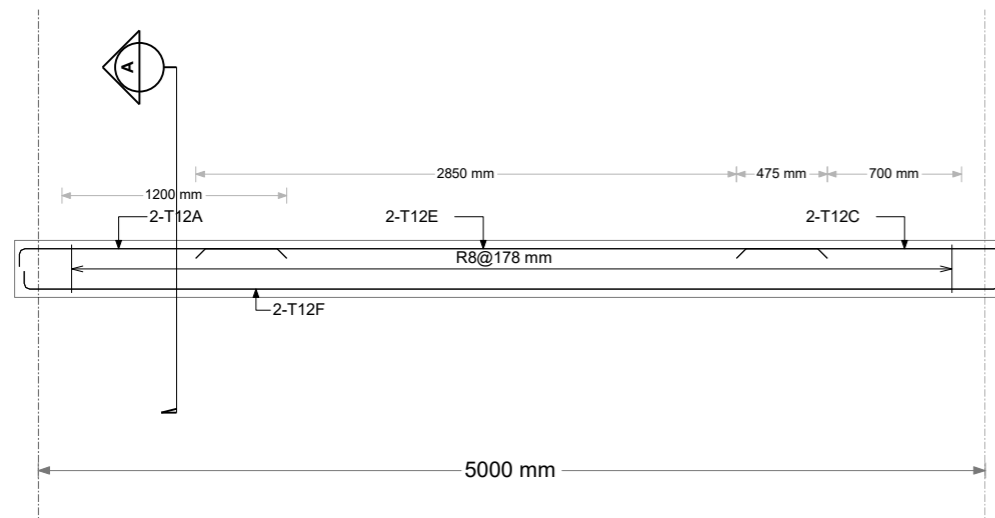

**1CB3:Elevation**  
(Scale = 3/8"=1'-0")

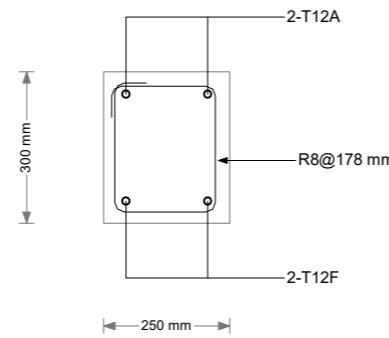

**1CB3:Section A**  
(Scale = 3/4"=1'-0")

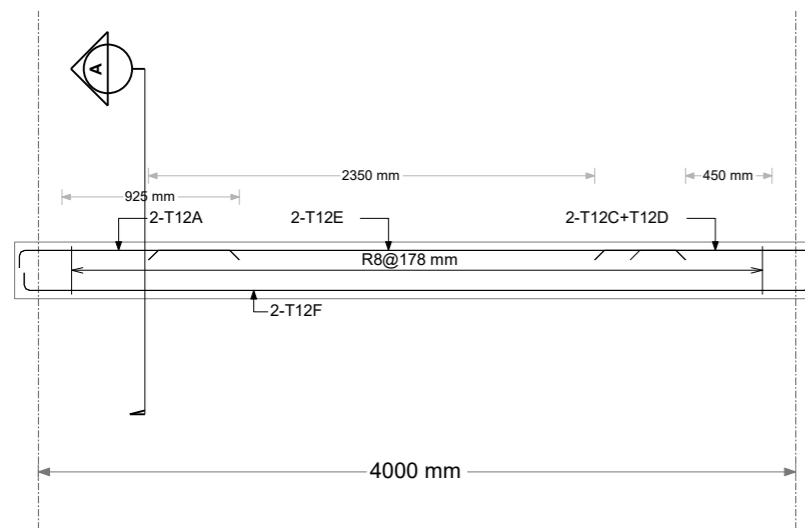

**1CB4:Elevation**  
(Scale = 3/8"=1'-0")

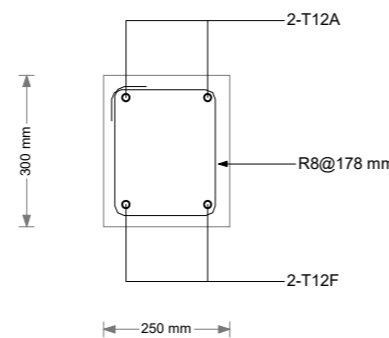

**1CB4:Section A**  
(Scale = 3/4"=1'-0")

**GENERAL NOTES**

- USE CONCRETE C-25 FOR COLUMNS, SLABS, BEAMS, AND FOOTING
- USE CONCRETE C-5 FOR LEAN CONCRETE
- USE 25mm CONCRETE COVER TO BEAMS, COLUMNS & SLAB
- USE 40mm CONCRETE COVER TO FOOTINGS
- USE CLASS S-400 DEFORMED REINFORCEMENT BARS REINFORCING STEEL FY=400N/MM2
- ACTUAL SOIL BEARING CAPACITY SHALL BE CHECKED BY THE SUPERVISING ENGINEER DURING ACTUAL EXCAVATION FOR FOUNDATION.
- MAXIMUM SIZE OF AGGREGATE =20mm
- FOUNDATION DEPTH SHALL BE DECIDED BY THE ENG. ON SITE
- ALL DIMENSIONS ARE IN mm BE SCALED
- THE DIMENSIONS IN DRAWINGS SHOULD NOT
- THIS DRAWING SHOULD READ IN CONNECTION WITH ARCHITECTURAL, SANITARY, AND ELECTRICAL

No.	Date	Description

Drawing status  
**STRUCTURAL DRAWING**

CLIENT  
**ACTED SOUTH SUDAN**

CONSULTANT  
**LADDER FOR ENGINEERING AND GENERAL INVESTMENT CO.LTD**

PROJECT  
**1500 MT WAREHOUSE**

LOCATION  
**NAMRABIA, IBBA COUNTY, WESTERN EQUATORIAL STATE, RSS**

DRAWING TITLE  
**RC Frame layout, Elevations and Sections**

DESIGN & DRAWING BY. \_\_\_\_\_ Date \_\_\_\_\_  
**LADDER ENGINEERING**

CHECKED & APPROVED BY \_\_\_\_\_ Date \_\_\_\_\_

Scales  
**AS SHOWN**

Layout ID. **A02-6** Revision \_\_\_\_\_



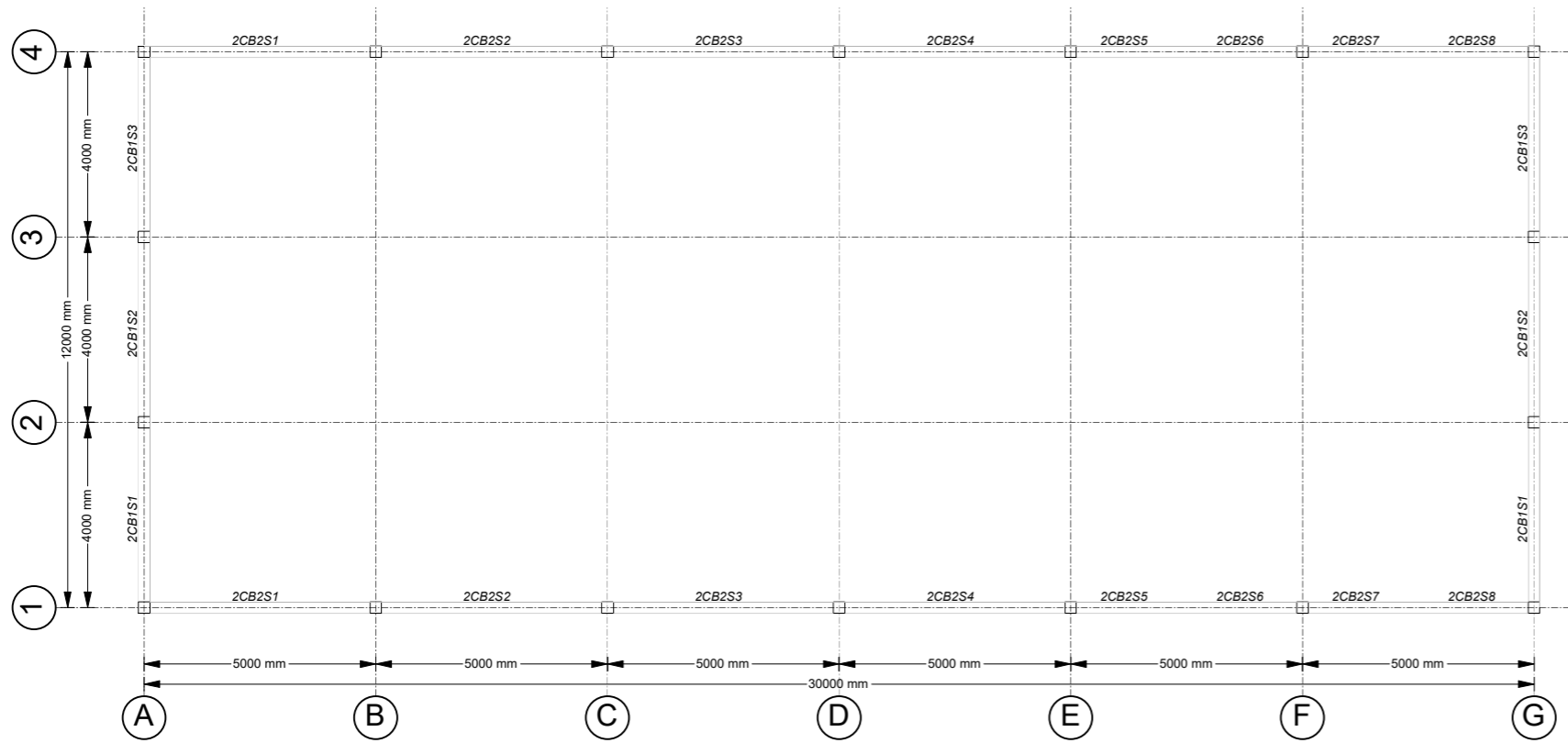

Concrete Beam Layout - Story2 (EL. 6000 mm)  
(Scale = 1/12"=1'-0")

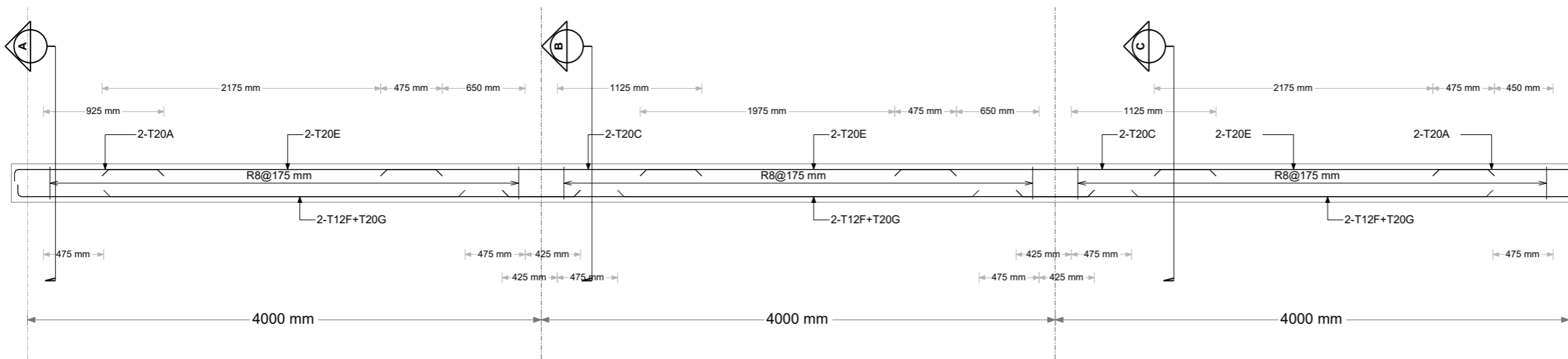

2CB1:Elevation  
(Scale = 3/8"=1'-0")

**GENERAL NOTES**

- USE CONCRETE C-25 FOR COLUMNS, SLABS, BEAMS, AND FOOTING
- USE CONCRETE C-5 FOR LEAN CONCRETE
- USE 25mm CONCRETE COVER TO BEAMS, COLUMNS & SLAB
- USE 40mm CONCRETE COVER TO FOOTINGS
- USE CLASS S-400 DEFORMED REINFORCEMENT BARS REINFORCING STEEL FY=400N/MM2
- ACTUAL SOIL BEARING CAPACITY SHALL BE CHECKED BY THE SUPERVISING ENGINEER DURING ACTUAL EXCAVATION FOR FOUNDATION.
- MAXIMUM SIZE OF AGGREGATE =20mm
- FOUNDATION DEPTH SHALL BE DECIDED BY THE ENG. ON SITE
- ALL DIMENSIONS ARE IN mm BE SCALED
- THE DIMENSIONS IN DRAWINGS SHOULD NOT BE SCALED
- THIS DRAWING SHOULD READ IN CONNECTION WITH ARCHITECTURAL, SANITARY, AND ELECTRICAL

No.	Date	Description
-----	------	-------------

Drawing status  
**STRUCTURAL DRAWING**

CLIENT  
**ACTED SOUTH SUDAN**

CONSULTANT  
**LADDER FOR ENGINEERING AND GENERAL INVESTMENT CO.LTD**

PROJECT  
**1500 MT WAREHOUSE**

LOCATION  
**NAMRABIA, IBBA COUNTY, WESTERN EQUATORIAL STATE, RSS**

DRAWING TITLE  
**RC Frame layout, Elevations and Sections**

DESIGN & DRAWING BY. \_\_\_\_\_ Date \_\_\_\_\_  
**LADDER ENGINEERING**

CHECKED & APPROVED BY \_\_\_\_\_ Date \_\_\_\_\_

Scales  
**AS SHOWN**

Layout ID. \_\_\_\_\_ Revision \_\_\_\_\_  
**A02-7**

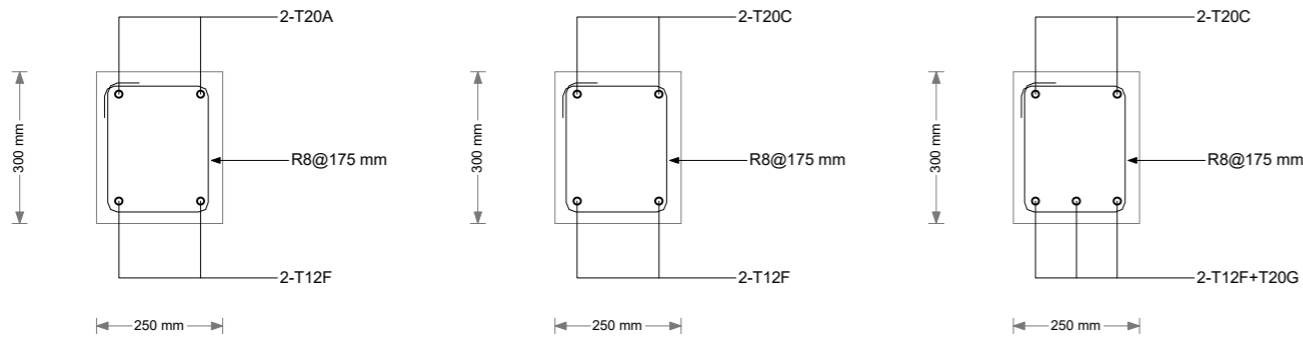

**2CB1:Section A**  
(Scale = 3/4"=1'-0")

**2CB1:Section B**  
(Scale = 3/4"=1'-0")

**2CB1:Section C**  
(Scale = 3/4"=1'-0")

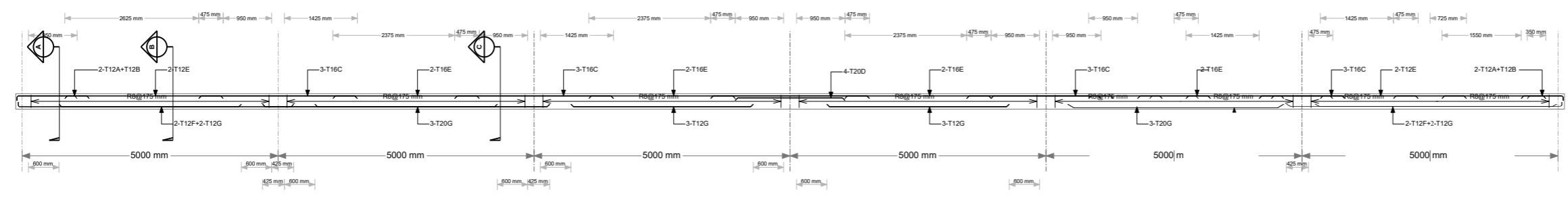

**2CB2:Elevation**  
(Scale = 1/8"=1'-0")

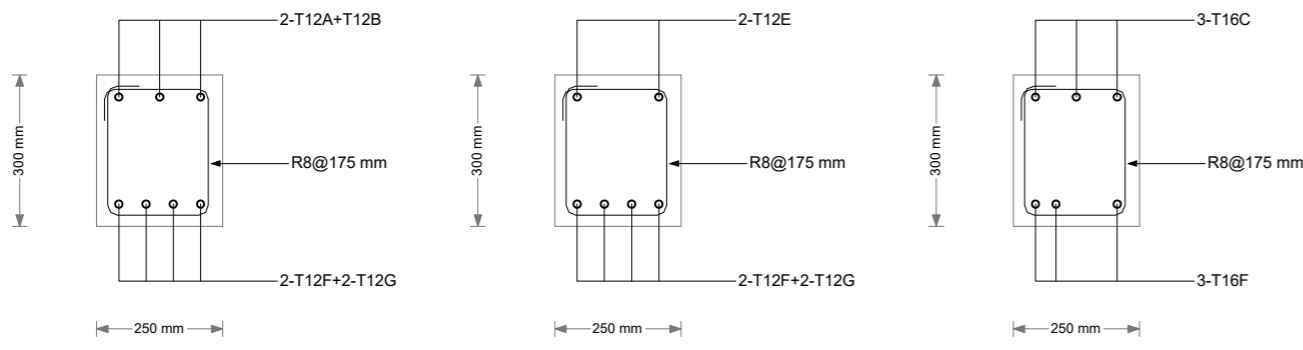

**2CB2:Section A**  
(Scale = 3/4"=1'-0")

**2CB2:Section B**  
(Scale = 3/4"=1'-0")

**2CB2:Section C**  
(Scale = 3/4"=1'-0")

**GENERAL NOTES**

- USE CONCRETE C-25 FOR COLUMNS, SLABS, BEAMS, AND FOOTING
- USE CONCRETE C-5 FOR LEAN CONCRETE
- USE 25mm CONCRETE COVER TO BEAMS, COLUMNS & SLAB
- USE 40mm CONCRETE COVER TO FOOTINGS
- USE CLASS S-400 DEFORMED REINFORCEMENT BARS
- REINFORCING STEEL FY=400N/MM<sup>2</sup>
- ACTUAL SOIL BEARING CAPACITY SHALL BE CHECKED BY THE SUPERVISING ENGINEER DURING ACTUAL EXCAVATION FOR FOUNDATION.
- MAXIMUM SIZE OF AGGREGATE =20mm
- FOUNDATION DEPTH SHALL BE DECIDED BY THE ENG. ON SITE
- ALL DIMENSIONS ARE IN mm
- BE SCALED
- THE DIMENSIONS IN DRAWINGS SHOULD NOT
- THIS DRAWING SHOULD READ IN CONNECTION WITH ARCHITECTURAL, SANITARY , AND ELECTRICAL

No.	Date	Description

Drawing status  
**STRUCTURAL DRAWING**

CLIENT  
**ACTED SOUTH SUDAN**

CONSULTANT  
**LADDER FOR ENGINEERING AND GENERAL INVESTMENT CO.LTD**

PROJECT  
**1500 MT WAREHOUSE**

LOCATION  
**NAMRABIA, IBBA COUNTY, WESTERN EQUATORIAL STATE, RSS**

DRAWING TITLE  
**RC Frame layout, Elevations and Sections**

DESIGN & DRAWING BY. \_\_\_\_\_ Date \_\_\_\_\_  
**LADDER ENGINEERING**

CHECKED & APPROVED BY \_\_\_\_\_ Date \_\_\_\_\_

Scales  
**AS SHOWN**

Layout ID. \_\_\_\_\_ Revision \_\_\_\_\_  
**A02-8**

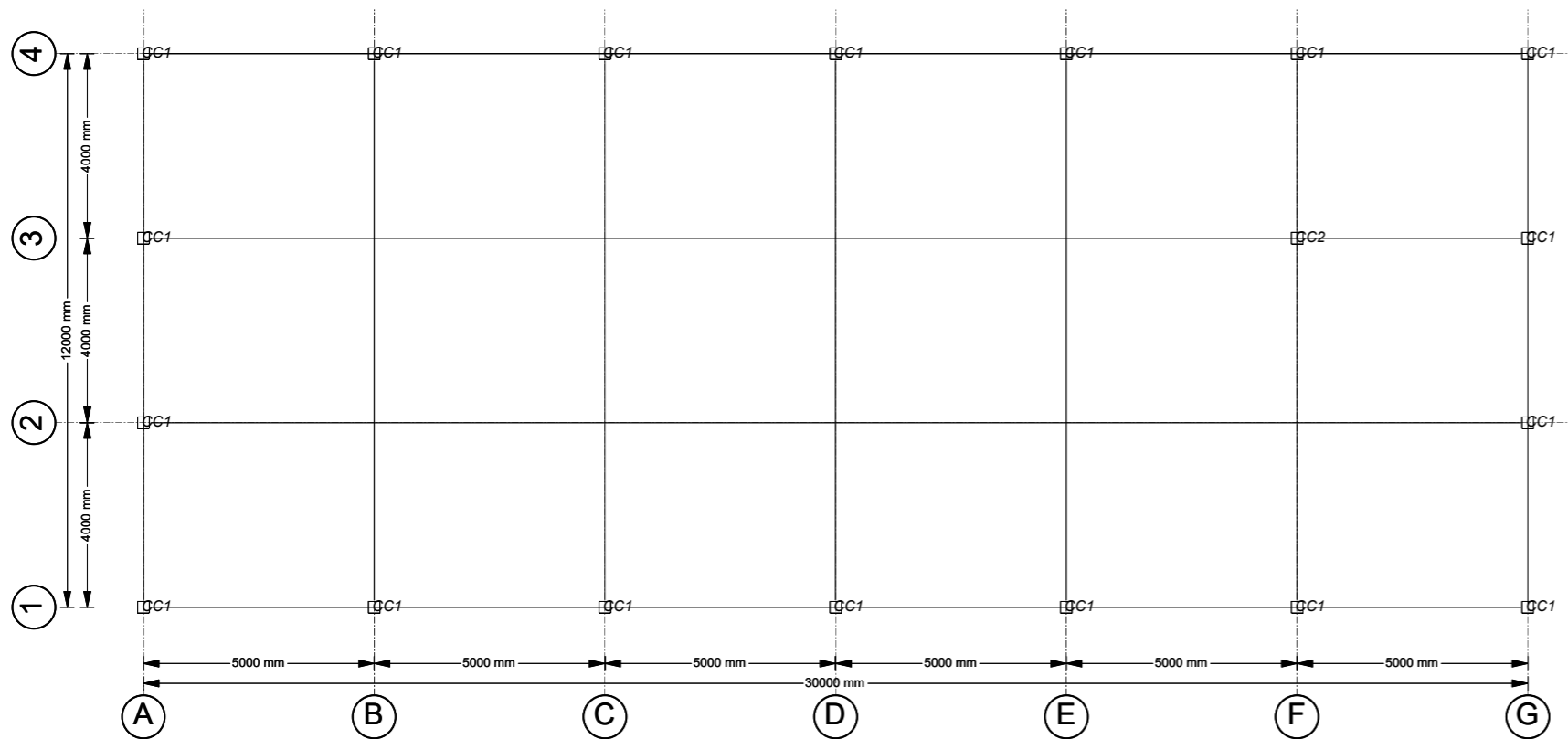

Concrete Column Layout - Base (EL. 0 mm)  
(Scale = 1/12"=1'-0")

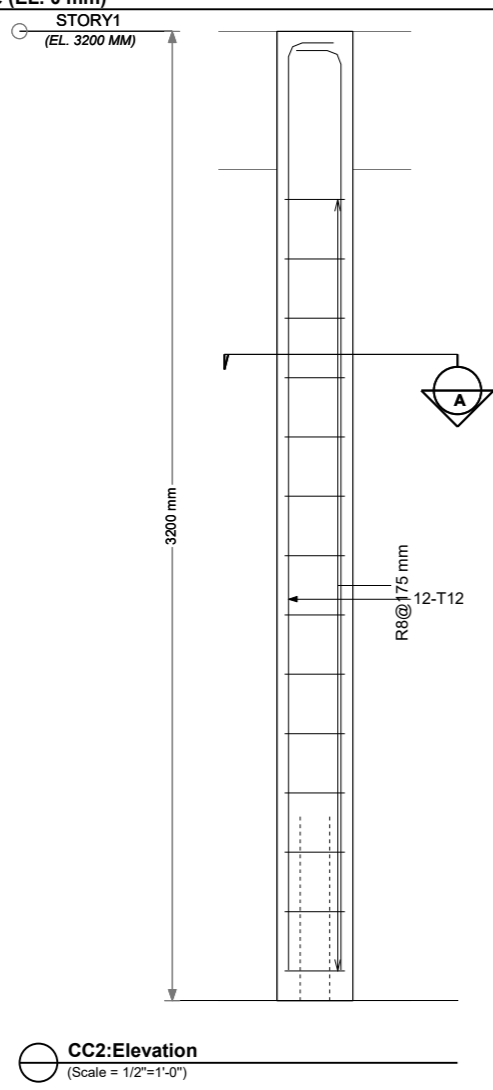

CC2:Elevation  
(Scale = 1/2"=1'-0")

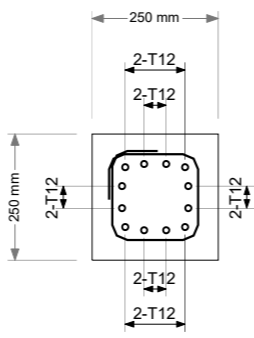

CC2:Section A  
(Scale = 3/4"=1'-0")

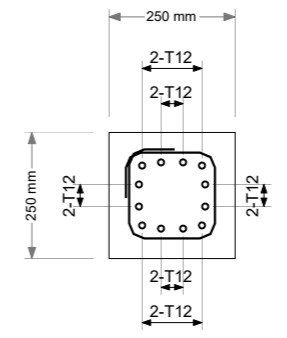

CC1:Section A  
(Scale = 3/4"=1'-0")

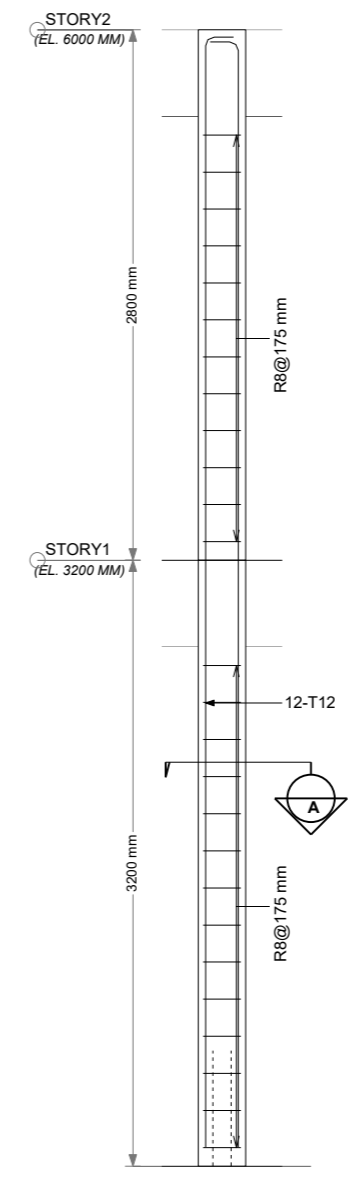

CC1:Elevation-1  
(Scale = 3/8"=1'-0")

**GENERAL NOTES**

- USE CONCRETE C-25 FOR COLUMNS, SLABS, BEAMS, AND FOOTING
- USE CONCRETE C-5 FOR LEAN CONCRETE
- USE 25mm CONCRETE COVER TO BEAMS, COLUMNS & SLAB
- USE 40mm CONCRETE COVER TO FOOTINGS
- USE CLASS S-400 DEFORMED REINFORCEMENT BARS REINFORCING STEEL  $F_y = 400N/MM^2$
- ACTUAL SOIL BEARING CAPACITY SHALL BE CHECKED BY THE SUPERVISING ENGINEER DURING ACTUAL EXCAVATION FOR FOUNDATION.
- MAXIMUM SIZE OF AGGREGATE = 20mm
- FOUNDATION DEPTH SHALL BE DECIDED BY THE ENG. ON SITE
- ALL DIMENSIONS ARE IN mm BE SCALED
- THE DIMENSIONS IN DRAWINGS SHOULD NOT BE SCALED
- THIS DRAWING SHOULD READ IN CONNECTION WITH ARCHITECTURAL, SANITARY, AND ELECTRICAL

No.	Date	Description

Drawing status  
**STRUCTURAL DRAWING**

CLIENT  
**ACTED SOUTH SUDAN**

CONSULTANT  
**LADDER FOR ENGINEERING AND GENERAL INVESTMENT CO.LTD**

PROJECT  
**1500 MT WAREHOUSE**

LOCATION  
**NAMRABIA, IBBA COUNTY, WESTERN EQUATORIAL STATE, RSS**

DRAWING TITLE  
**RC Frame layout, Elevations and Sections**

DESIGN & DRAWING BY. \_\_\_\_\_ Date \_\_\_\_\_  
**LADDER ENGINEERING**

CHECKED & APPROVED BY \_\_\_\_\_ Date \_\_\_\_\_

Scales  
**AS SHOWN**

Layout ID. \_\_\_\_\_ Revision \_\_\_\_\_  
**A02-9**

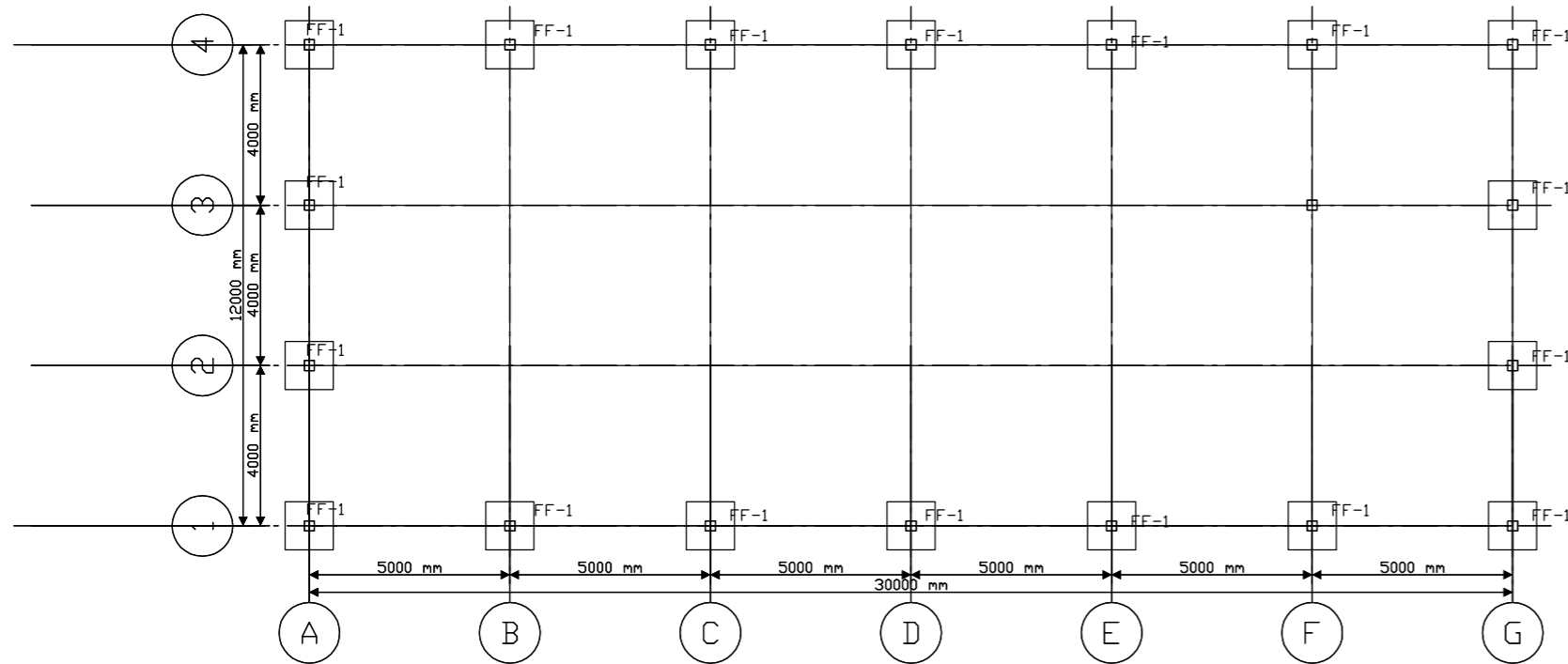

Isolated Footing layout - Base (El. -1200mm)  
(Scale 1:150)

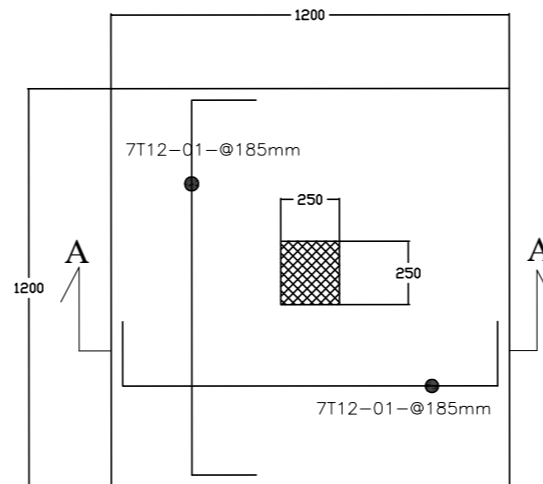

ISOLATED FOOTING F-1 (18- PCS)  
SCALE 1 : 25

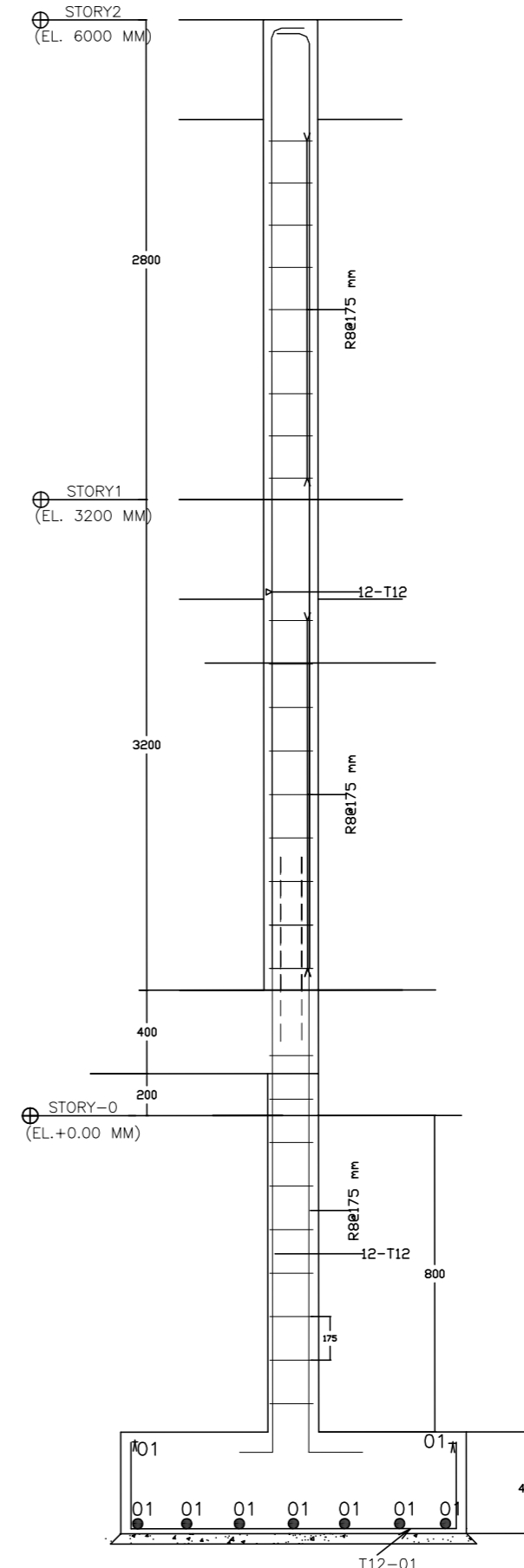

SECTION A-A  
SCALE 1:25

**GENERAL NOTES**

- USE CONCRETE C-25 FOR COLUMNS, SLABS, BEAMS, AND FOOTING
- USE CONCRETE C-5 FOR LEAN CONCRETE
- USE 25mm CONCRETE COVER TO BEAMS, COLUMNS & SLAB
- USE 40mm CONCRETE COVER TO FOOTINGS
- USE CLASS S-400 DEFORMED REINFORCEMENT BARS REINFORCING STEEL  $F_y=400N/MM^2$
- ACTUAL SOIL BEARING CAPACITY SHALL BE CHECKED BY THE SUPERVISING ENGINEER DURING ACTUAL EXCAVATION FOR FOUNDATION.
- MAXIMUM SIZE OF AGGREGATE = 20mm
- FOUNDATION DEPTH SHALL BE DECIDED BY THE ENG. ON SITE
- ALL DIMENSIONS ARE IN mm BE SCALED
- THE DIMENSIONS IN DRAWINGS SHOULD NOT
- THIS DRAWING SHOULD READ IN CONNECTION WITH ARCHITECTURAL, SANITARY, AND ELECTRICAL

No.	Date	Description

Drawing status  
**STRUCTURAL DRAWING**

CLIENT  
**ACTED SOUTH SUDAN**

CONSULTANT  
**LADDER FOR ENGINEERING AND GENERAL INVESTMENT CO.LTD**

PROJECT  
**1500 MT WAREHOUSE**

LOCATION  
**NAMRABIA, IBBA COUNTY, WESTERN EQUATORIAL STATE, RSS**

DRAWING TITLE  
**RC Frame layout, Elevations and Sections**

DESIGN & DRAWING BY. \_\_\_\_\_ Date \_\_\_\_\_

**LADDER ENGINEERING**

CHECKED & APPROVED BY \_\_\_\_\_ Date \_\_\_\_\_

Scales  
**AS SHOWN**

Layout ID. **A02-10** Revision \_\_\_\_\_